



INSTALLER AND OWNER GUIDE

Please keep me in a safe place for future use.

Model 961

Inset live fuel effect gas fire

Incorporating the Wonderfire Premier **FireSlide**® Control.

Fitted with one of the following fascia:

Bauhaus, Bloomsbury or Ebony.

(G.C. Number 32-032-88)



We trust that this guide gives sufficient details to enable this appliance to be installed, operated and maintained satisfactorily. However, if further information is required, our **Wonderfire premier Technical Helpline** will be pleased to help. Telephone **0844 8711 565** (National call rates apply in the United Kingdom). In the Republic of Ireland Telephone **0044 844 8711 565**.



THIS APPLIANCE IS FOR USE WITH NATURAL GAS (G20).

**UNDER NO CIRCUMSTANCES IS THIS FIRE TO BE CONVERTED TO LPG.
AN LPG KIT DOES NOT EXIST FOR THIS GAS FIRE.**

**THIS APPLIANCE IS SUITABLE ONLY FOR INSTALLATION IN THE UNITED
KINGDOM (GB) AND THE REPUBLIC OF IRELAND (IE).**

© GDC Group Ltd. 2011.

All rights reserved. No part of this publication may be reproduced in any material form (including photocopying), stored in any medium by electronic means (including in any retrieval system or database) or transmitted, in any form or by any means, whether electronic, mechanical, recording or otherwise, without the prior written permission of the copyright owner.

Applications for the copyright owner's permission to reproduce any part of this publication should be made, giving details of the proposed use, to the following address: The Marketing Communications Manager, GDC Group Ltd, Millbrook House, Grange Dive, Hedge End, Southampton, SO30 2DF.

Warning: Any person who does any unauthorised act in relation to a copyright work may be liable to criminal prosecution and civil claims for damages.



Wonderfire Premier, Erdington, Birmingham B24 9QP
www.firesandstoves.co.uk

Because our policy is one of constant development and improvement, details may vary slightly from those given in this publication

Safety First.

Wonderfire Premier fires are CE Approved and designed to meet the appropriate British Standards and Safety Marks.



Quality and Excellence.

All Wonderfire Premier fires are manufactured to the highest standards of quality and excellence and are manufactured under a BS EN ISO 9001 quality system accepted by the British Standards Institute.



The Highest Standards

Wonderfire is a member of SBGI and HHIC (Heating and Hot water Industry Council) that work to ensure high standards of safety, quality and performance.



Careful Installation

This gas fire must be installed by a competent GAS SAFE REGISTER operative in accordance with our installer guide and should not be fitted directly on to a carpet or floor of combustible material.



INSTALLER GUIDE

FOR OWNER GUIDE SEE PAGES 48 TO 67

INSTALLER GUIDE

CONTENTS

<u>Section</u>	<u>Heading</u>	<u>Page</u>
	INSTALLER GUIDE	4 - 47
	OWNER GUIDE	48 - 67
1.	IMAGES	7
2.	SAFETY AND UNPACKING	8
3.	APPLIANCE DATA, EFFICIENCY AND NO_x	9
	3.1 General information.	9
	3.2 Efficiency.	10
	3.3 NO _x	10
4.	GENERAL INSTALLATION REQUIREMENTS	11
	4.1 Regulations, Standards and Law.	11
	4.2 Ventilation requirements.	12
	4.3 The Atmosphere sensing device (ASD).	12
	4.4 Fireguard requirements.	12
	4.5 Room considerations.	12
	4.6 Chimney preparation.	12
	4.7 Fireplace preparation.	13
	4.8 The hearth and surround.	13
	4.9 Fireplace clearances.	14
	4.10 Installation options.	16
	4.11 Flues.	19
5.	PACK CONTENTS	20
6.	FIREPLACE CHECK	23
7.	IGNITION CHECK	24
8.	GAS SUPPLY CONNECTION	24
9.	PREPARING APPLIANCE FOR INSTALLATION	25
10.	CONVECTION BOX INSTALLATION	27
	10.1 Method 1 - Front fixing to fireplace surround.	27
	10.2 Method 2 - Cable retention and floor fixing.	28
	10.3 Sealing floor front - All installations.	30
11.	BURNER AND SUPPLY PIPE INSTALLATION	31
	11.1 Burner and supply pipe installation.	31
	11.2 Preliminary burner checks.	31
	11.3 Inlet pressure check.	32

Continued on next page

INSTALLER GUIDE

CONTENTS (CONTINUED)

<u>Section</u>	<u>Heading</u>	<u>Page</u>
12.	FITTING THE CERAMIC FUEL EFFECT	32
13.	FITTING THE WINDOW FRAME ASSEMBLY	33
14.	OPERATING AND SPILLAGE CHECKS	33
14.1	Fitting the control knob extension on the Bloomsbury model.	33
14.2	Checking the control settings.	33
14.3	Check for spillage.	34
14.4	Flame supervision and spillage monitoring system.	35
15.	OUTLET BAFFLE AND FASCIA FITTING	36
15.1	Fitting the outlet baffle.	36
15.2	Fitting the fascia.	36
15.3	Fitting the firefront casting / lower firefront casting.	37
16.	FINAL REVIEW	38
17.	SERVICING & PARTS REPLACEMENT	39
17.1	Checking the aeration setting of the burner.	40
17.2	To remove the ignition microswitch.	40
17.3	To remove the gas shut-off microswitch.	40
17.4	To remove the fascia.	41
17.5	To replace the control slide unit.	42
17.6	To replace the control slide button.	42
17.7	To remove and fit the window mounting frame and window assembly.	43
17.8	To remove the window assembly.	43
17.9	To remove the fuel effect.	44
17.10	To remove the ceramic side walls.	44
17.11	To remove the electronic ignition generator.	44
17.12	To remove the complete burner unit.	45
17.13	To remove the thermocouple interrupter block (See figure 36).	45
17.14	To remove the pilot unit.	45
17.15	To remove the shut-off tap.	45
17.16	To remove the gas flow rate controller.	46
17.17	To replace the burner.	47
17.18	To remove the main burner injector.	47
17.19	To remove the appliance from the fireplace.	47

INSTALLER GUIDE

1. IMAGE

Ebony fascia



Bauhaus fascia

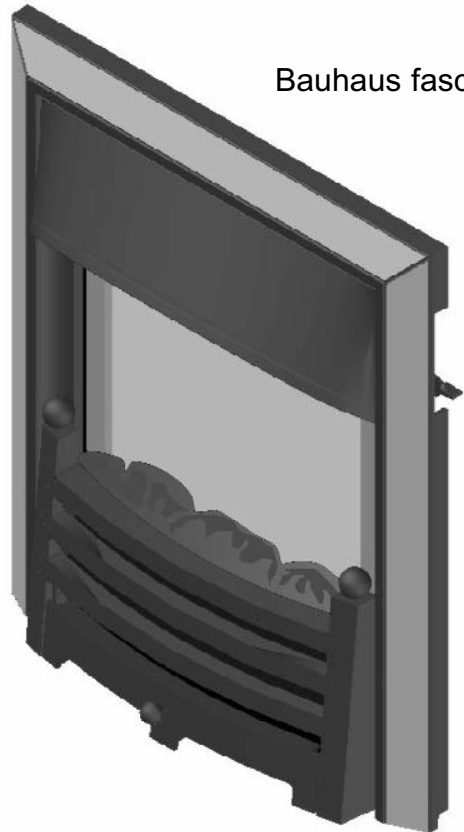

Bloomsbury fascia



INSTALLER GUIDE

2. SAFETY AND UNPACKING

Installer

Before continuing any further with the installation of this appliance please read the following guide to manual handling.

- The approximate lifting weight (kg) of this appliance is as below:

<u>Model</u>	<u>Heat Engine</u>	<u>Firefront</u>	<u>Combined Weight</u>
Bauhaus	8.64	12.00	20.64
Bloomsbury	8.64	7.22	15.86
Ebony	8.64	9.13	17.77

One person should be sufficient to lift the fire. If for any reason this weight is considered too heavy then obtain assistance.

- When lifting always keep your back straight. Bend your legs and not your back.
- Avoid twisting at the waist. It is better to reposition your feet.
- Avoid upper body/top heavy bending. Do not lean forward or sideways whilst handling the fire.
- Always grip with the palm of the hand. Do not use the tips of fingers for support.
- Always keep the fire as close to the body as possible. This will minimise the cantilever action.
- Use gloves to provide additional grip.
- Always use assistance if required.

This product uses fuel effect pieces and burner compartment walls containing Refractory Ceramic Fibres (RCF), which are man-made vitreous silicate fibres. Excessive exposure to these materials may cause irritation to eyes, skin and respiratory tract. Consequently, it is important to take care when handling these articles to ensure that the release of dust is kept to a minimum. To ensure that the release of fibres from these RCF articles is kept to a minimum, during installation and servicing we recommend that you use a HEPA filtered vacuum to remove any dust and soot accumulated in and around the fire before and after working on the fire. When replacing these articles we recommend that the replaced items are not broken up, but are sealed within a heavy duty polythene bag, clearly labelled as RCF waste. RCF waste is classed as a stable, non-reactive hazardous waste and may be disposed at a landfill licensed to accept such waste. Protective clothing is not required when handling these articles, but we recommend you follow the normal hygiene rules of not smoking, eating or drinking in the work area and always wash your hands before eating or drinking.

This appliance does not contain any component manufactured from asbestos or asbestos related products.

INSTALLER GUIDE

3. APPLIANCE DATA, EFFICIENCY AND NO_x

3.1 General information.

Gas	Natural (G20)
Inlet Pressure	20mbar
Input - Max. (Gross)	5.00kW (17,060 Btu/h)
Input - Min. (Gross)	2.5kW (8,530 Btu/h)
Input - Max. (Net)	4.5kW (15,371 Btu/h)
Input - Min. (Net)	2.25kW (7,677 Btu/h)
Inlet Test Pressure (Cold)	20.0 ± 1.0mbar (8.0 ± 0.4in w.g.)
Gas Connection	8mm pipe
Burner Injector	Cat 82 - 065
Pilot & Atmosphere Sensing Device	Copreci Ref. O.D.S 21500/166
Ignition	Electronic (Alkaline Battery 9V PP3)
Aeration Setting	Factory set - See section 17.1

Under no circumstances is this fire to be converted to LPG. An LPG conversion kit does **not** exist for this gas fire.

The appliance information label is located on a chained plate at the base of the fire. This can be seen by removing fire front / fire front casting.

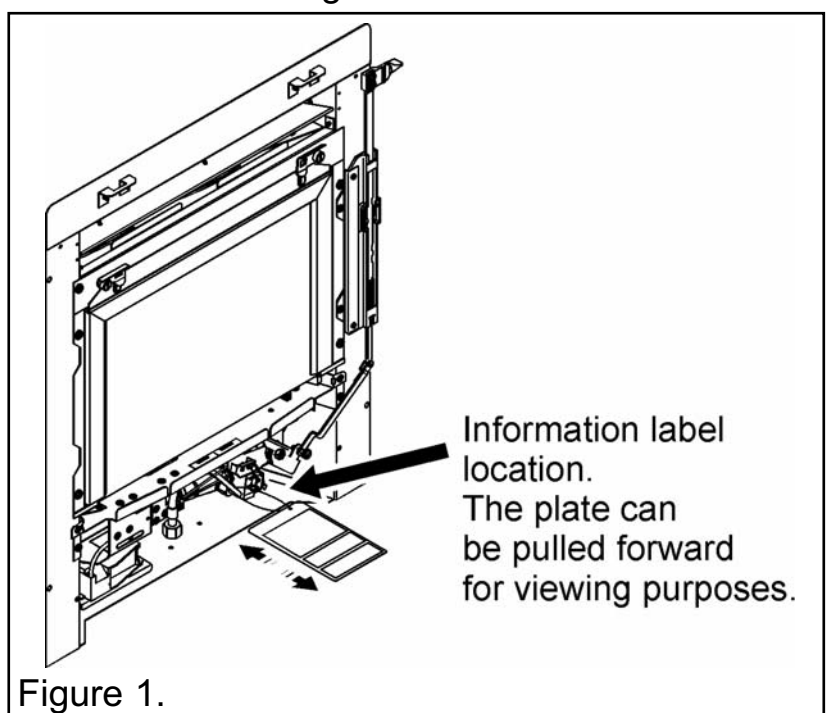

INSTALLER GUIDE

3.2 Efficiency.

The efficiency of this appliance has been measured as specified in BS 7977 - 1 and the result is as below:

<u>Model</u>	<u>Efficiency % (Gross)</u>	<u>Efficiency % (Net)</u>
961	80	89

The gross calorific value of the fuel has been used for this efficiency calculation. The test data from which it has been calculated has been certified by Advantica Certification services (0087). The efficiency value may be used in the UK Government's Standard Assessment Procedure (SAP) for energy rating of dwellings.

The conversion of **net** efficiency to **gross** was achieved by multiplying the net efficiency by the following conversion factor from Table E3 of SAP 2005, rounding down to the nearest whole number.

Gas	Conversion factor from net to gross efficiency
Natural Gas	0.901

3.3 NO_x

The 'Weighted' result for this appliance equates to NO_x Class II.

4. GENERAL INSTALLATION REQUIREMENTS

4.1 Regulations, Standards and Law.

The installation must be in accordance with these instructions.

For the user's protection, in the United Kingdom it is the law that all gas appliances are installed by competent persons in accordance with the current edition of the Gas Safety (Installation and Use) Regulations. Failure to install the appliance correctly could lead to prosecution. GAS SAFE REGISTER require their members to work to recognised standards.

In the United Kingdom the installation must also be in accordance with:

All the relevant parts of local regulations.

All relevant codes of practice.

The relevant parts of the current editions of the following British Standards:-

BS EN 1856 Part 1 - Chimneys - Requirements for metal chimneys.

BS 715 - Specification for metal flue boxes for gas-fired appliances not exceeding 20kW.

BS EN 1858 - Chimneys - Components - Concrete flue blocks.

BS EN 1806 - Chimneys - Clay / ceramic flue blocks.

BS 5440 Part 1 - Installation of flues.

BS 5440 Part 2 - Installation and maintenance of flues and ventilation for gas appliances of rated input not exceeding 70 kW net (1st, 2nd and 3rd family gases).

BS 6461 Part 1 - Masonry chimney & flues - Installation

BS 1251 - Fireplace components

BS 5871 Part 2 - Installation - Inset LFE gas fires

BS 6891 - Gas pipework installation

- In England and Wales, the current edition of the Building Regulations issued by the Department of the Environment and the Welsh Office.
- In Scotland, the current edition of the Building Standards (Scotland) Regulations issued by the Scottish Executive.
- In Northern Ireland, the current edition of the Building regulations (Northern Ireland) issued by the Department of the Environment for Northern Ireland.
- In the republic of Ireland the installation must be carried out by a competent person and also conform to the relevant parts of:
 - a) The current edition of IS 813 "Domestic Gas Installations".
 - b) All relevant national and local rules in force.

Where no specific instructions are given, reference should be made to the relevant British Standard Code of Practice.

4.2 Ventilation requirements.

Normal adventitious ventilation is usually sufficient to satisfy the ventilation requirements of this appliance. In GB reference should be made to BS 5871 Part 2 and in IE reference should be made to the current edition of IS 813 “Domestic Gas Installations” which makes clear the conditions that must be met to demonstrate that sufficient ventilation is available.

4.3 The Atmosphere sensing device (ASD).

The appliance is fitted with an A.S.D (Atmosphere sensing device). If the appliance closes down after a period of operation for no apparent reason, the consumer should be informed to stop using the appliance until the installation and appliance have been thoroughly checked. The A.S.D will shut the appliance down if an unacceptable amount of harmful products of combustion accumulate. Under no circumstances should the A.S.D be altered or bypassed in any way. Only a genuine manufacturer’s replacement part should be fitted. The individual A.S.D components are not replaceable.

4.4 Fireguard requirements.

A fireguard complying with BS 8423 should be fitted for the protection of young children, the elderly, the infirm and pet animals.

4.5 Room considerations.

4.5.1 This appliance must not be installed in any room that contains a bath or shower or where steam is regularly present.

4.5.2 An extractor fan may only be used in the same room as this appliance, or in any area from which ventilation for the appliance is taken, if it does not affect the safe performance of the appliance. Note the spillage test requirements detailed further on in this guide. If the fan is likely to affect the appliance, the appliance must not be installed unless the fan is permanently disconnected.

4.5.3 Note that soft wall coverings (e.g. embossed vinyl, etc.) are easily affected by heat. They may scorch or become discoloured when close to a heating appliance. Please bear this in mind when installing.

4.6 Chimney preparation.

4.6.1 If the appliance is intended to be installed to a chimney that was previously used for solid fuel, the flue must be swept clean prior to installation. All flues should be inspected for soundness and freedom from blockages.

4.6.2 Any chimney damper or restrictor should be removed. If removal is not possible, they must be secured in the open position.

INSTALLER GUIDE

4.7 Fireplace preparation.

4.7.1 If the fireplace opening is an underfloor draught type, it must be sealed to stop any draughts.

4.7.2 The fireplace floor should be reasonably flat to ensure that the convection box can be installed without it rocking and so that a good seal can be made at the bottom front of the box.

4.7.3 The front face of the fireplace should be reasonably flat over the area covered by the convection box top and side flange seals to ensure good sealing. These faces should be made good if necessary. The fireplace floor should be reasonably flat to ensure that a good seal with the convection box can be made.

4.7.4 If the appliance is to be fitted against a wall with combustible cladding, the cladding must be removed from the area covered by the fascia. The cladding must also not touch the fascia (See figure 2). We suggest that the actual fascia is used as a template to mark the area for combustible cladding removal and that this area is increased by at least 2mm all round.

4.7.5 If the fireplace opening is greater than the acceptable dimensions given in this guide, do not use the back of a fire surround or marble to reduce the opening. This may cause cracking of the surround back or marble.

4.8 The hearth and surround.

The appliance must be mounted behind a non-combustible hearth unless the conditions of section 4.10.1.1 are met (N.B. conglomerate marble hearths are considered as non-combustible). The appliance can be fitted to a purpose made proprietary class "O"-150°C surround. The hearth material must be at least 12mm thick. The periphery of the hearth (or fender) should be at least 50mm above floor level to discourage the placing of carpets or rugs over it.

The surface of the hearth must be sufficiently flat to enable the bottom of the front surround and the bottom front cover to be aligned horizontally. Any excessive unevenness (uneven tiles, Cotswold stone, etc.) should be rectified.

The appliance must not stand on combustible materials or carpets.

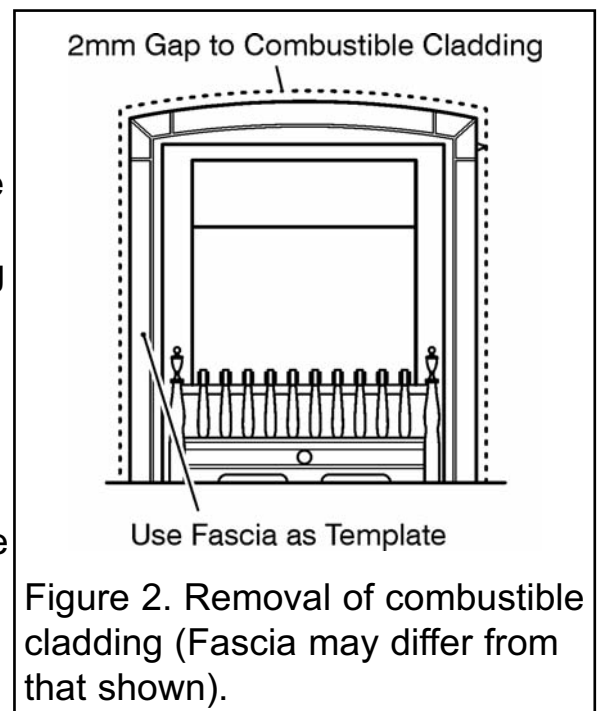

INSTALLER GUIDE

4.9 Fireplace clearances.

4.9.1 The minimum height from the base of the fireplace opening to the underside of any shelf made from wood or other combustible materials is detailed below.

For Bauhaus and Ebony models:-

- For a shelf up to 150mm deep: Minimum height = 700mm.
- For a shelf deeper than 150mm: 700mm + 12.5mm for every 25mm depth over 150mm (See Figure 3).

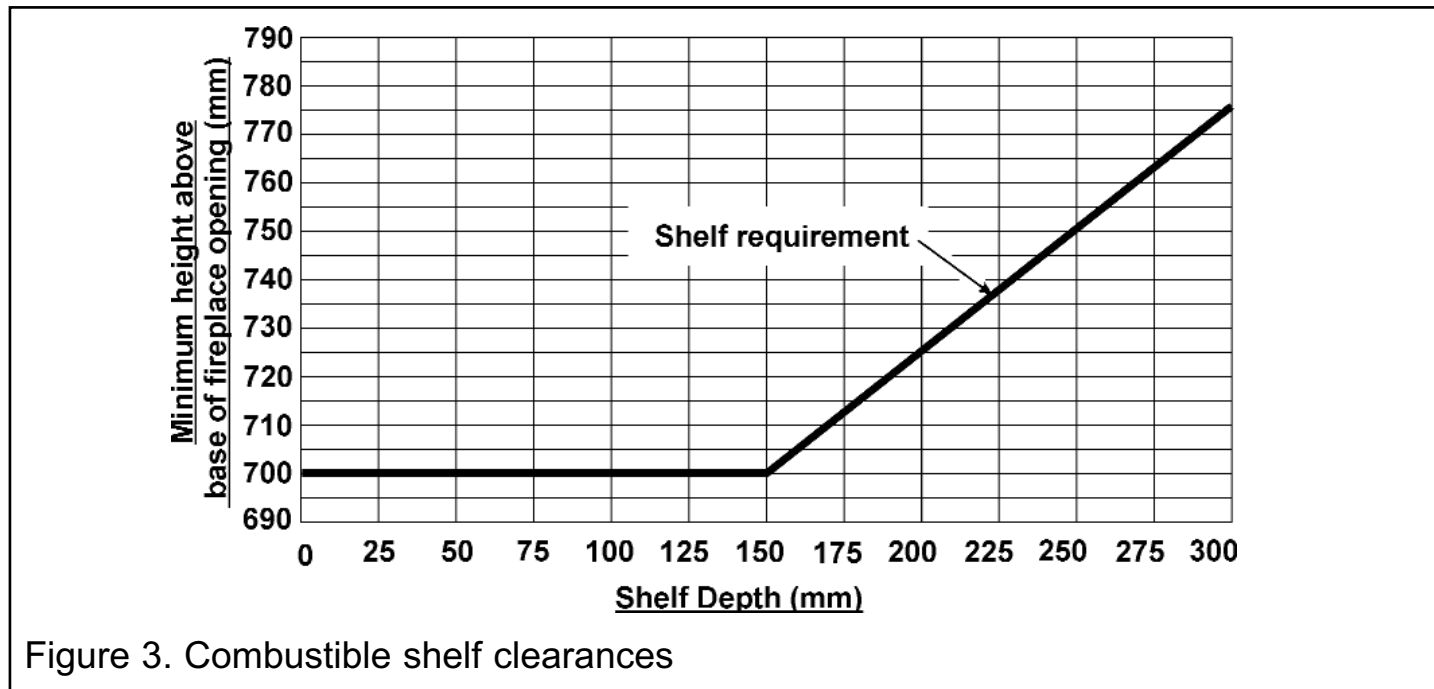

Figure 3. Combustible shelf clearances

For Bloomsbury models:-

- For a shelf up to 150mm deep: Minimum height = 775mm.
- For a shelf deeper than 150mm: 775mm + 12.5mm for every 25mm depth over 150mm (See Figure 4).

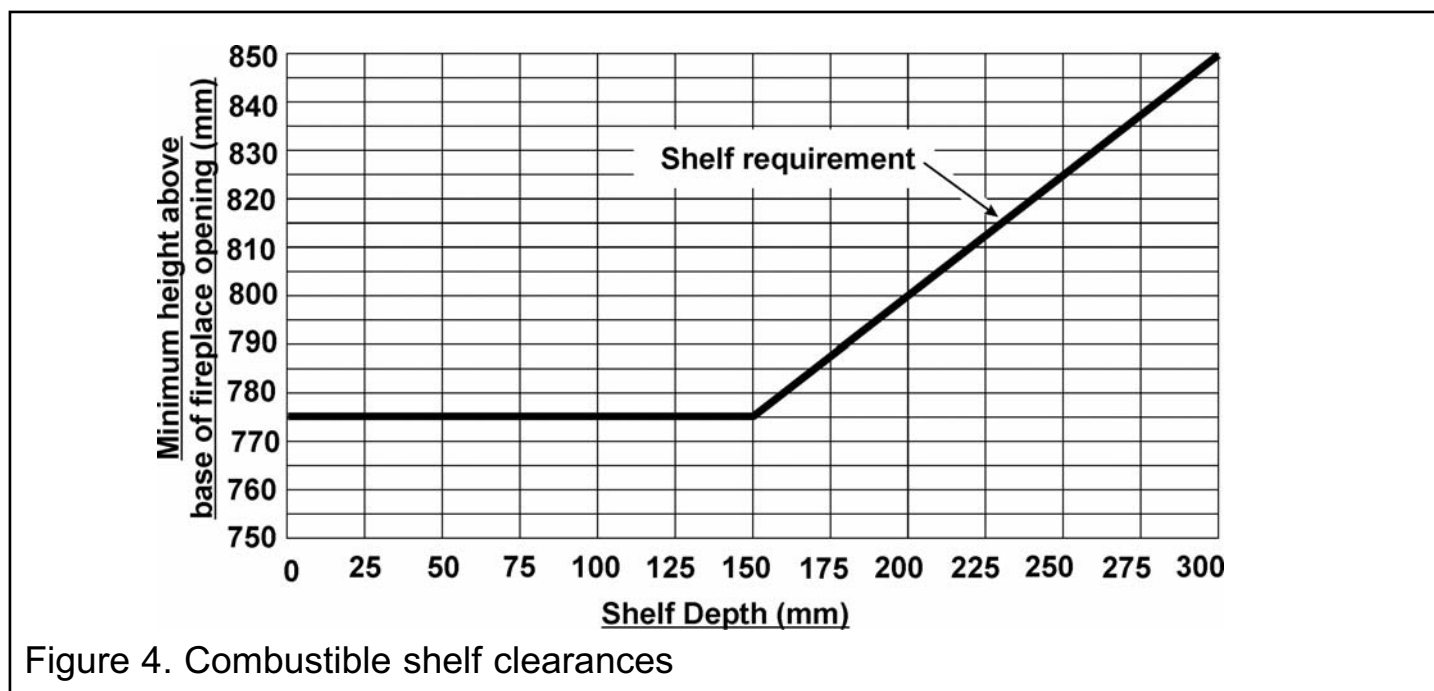
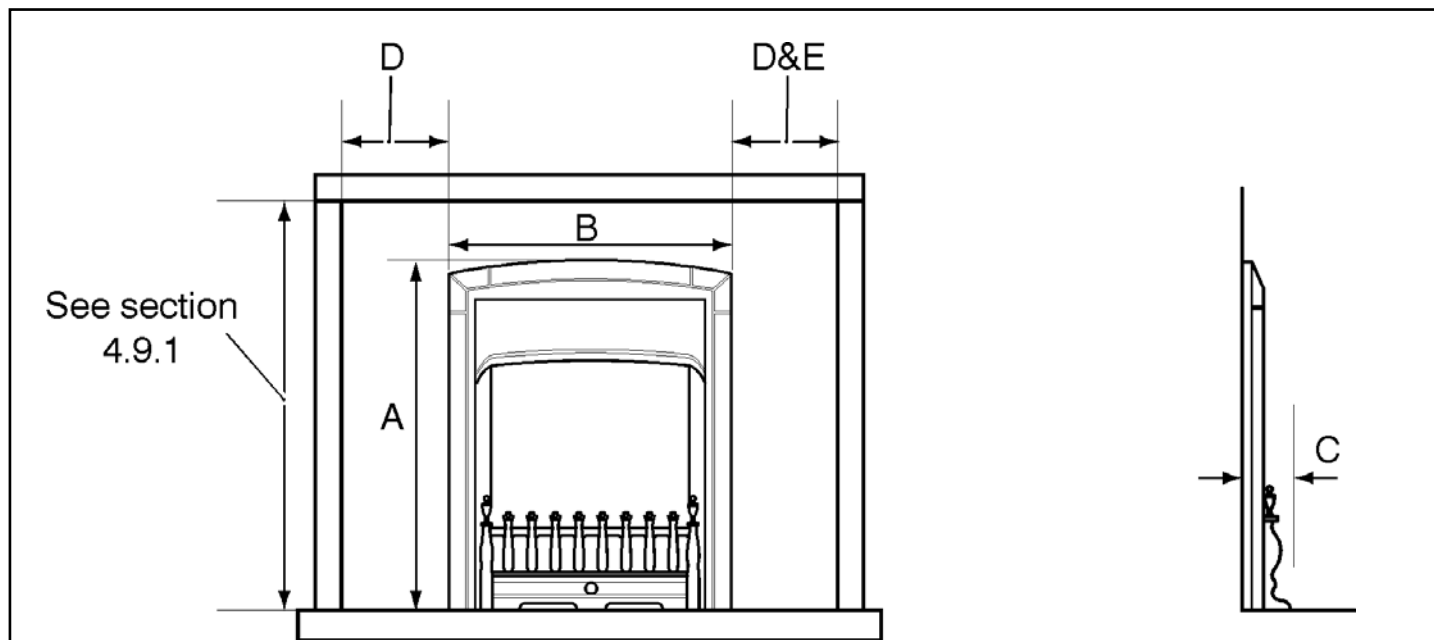

Figure 4. Combustible shelf clearances

INSTALLER GUIDE

4.9.2 The minimum allowable distance from the outside of the appliance fascia to a corner wall having combustible material or any other combustible surface which projects beyond the front of the appliance is shown in figure 5. A 10mm access clearance from a non-combustible surface is necessary at the left side.



Key	Description	Model		
		Bauhaus	Bloomsbury	Ebony
A	Height (mm)	616	741	616
B	Width (mm)	518	588	518
C	Depth into room (mm)	117	127	126
D	Minimum mandatory clearance to combustible surfaces projecting beyond the front of appliance (mm).	100	100	100
E	Recommended clearance to non-combustible surfaces for access purposes (mm).	50	50	50

Figure 5. Appliance dimensions and clearances (The fascia may differ from that shown and dimensions are subject to manufacturing tolerances)

INSTALLER GUIDE

4.10 Installation options.

In the United Kingdom, as supplied, the appliance can be installed in the following situations: -

4.10.1 Conventional fireplace and hearth.

To a fireplace complete with surround and hearth as shown in figure 6 and complying with BS1251 after removal of the fireback and sufficient material behind the fireback for a debris catchment space. The required fireplace, hearth, debris catchment area and clearance dimensions are shown in figure 7.

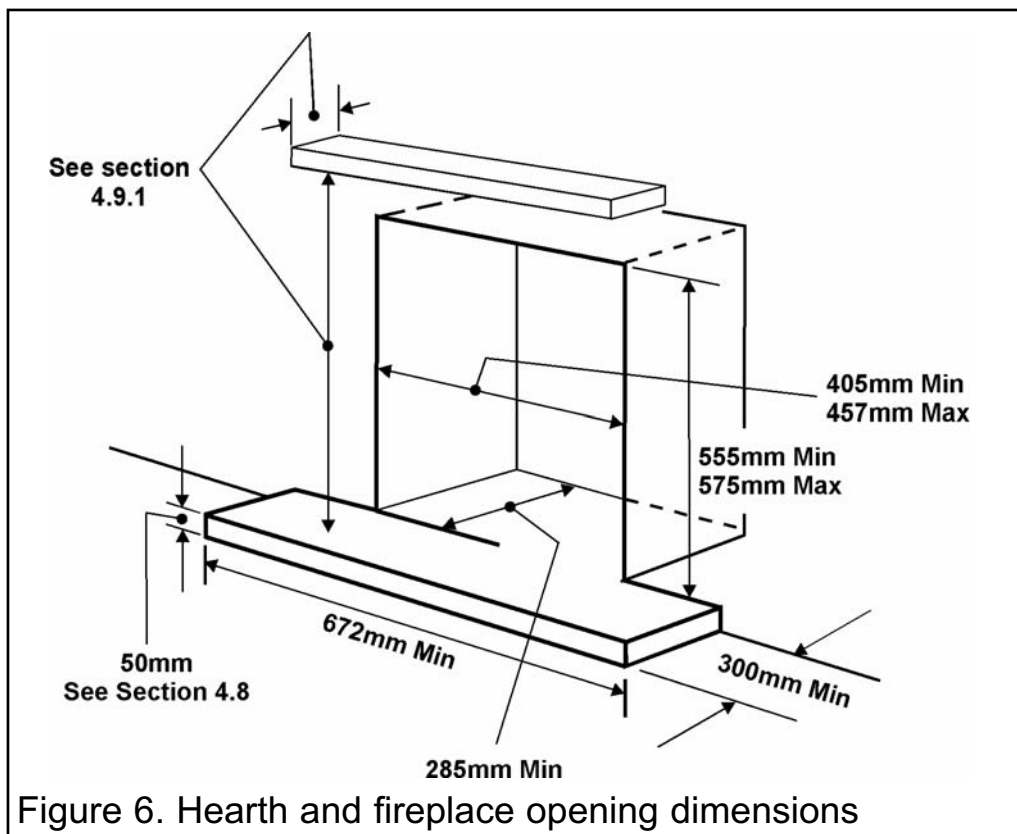

Figure 6. Hearth and fireplace opening dimensions

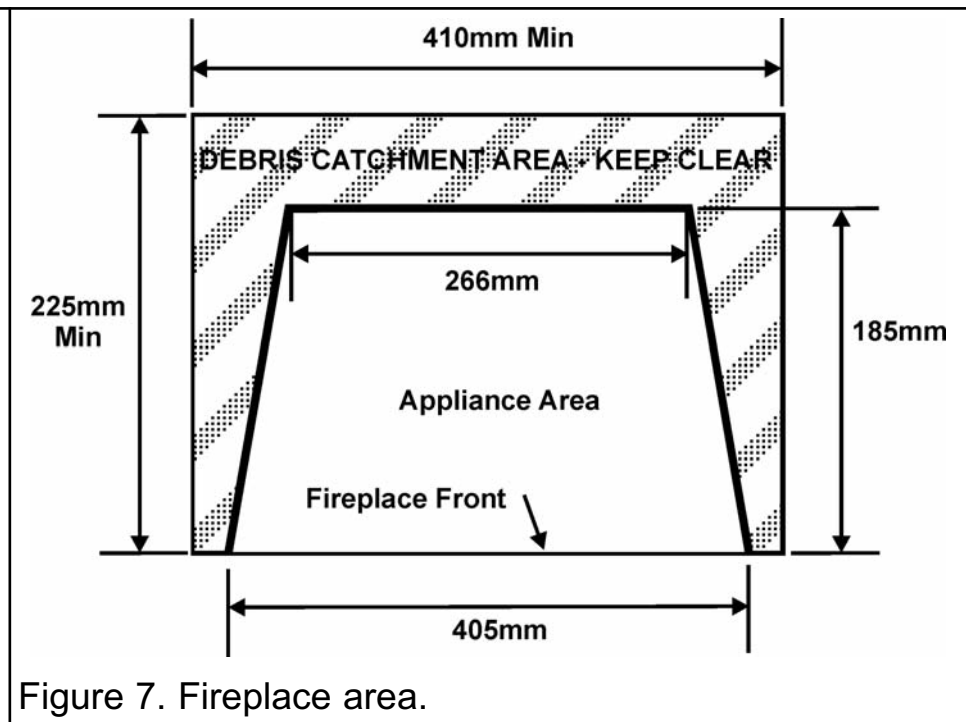

Figure 7. Fireplace area.

INSTALLER GUIDE

4.10.1.1 'Hole-in-the-wall' Installations.

- It is recommended that a hearth should be installed as in section 4.8.
- If a reduced depth hearth is fitted, the fire must be installed so that the distance from the base of the fireplace opening in the wall to the finished floor level is at least 100mm. It is recommended that the reduced hearth has a depth from the fixing plane of the fire of 100mm minimum. This is necessary to support the lower front casting. Where there is no floor covering or carpet and the floor is of a type that is likely to be covered in such a way in the future then the distance from the base of the fireplace opening in the wall to the floor level should be increased to at least 175mm.

4.10.2 Metal flue box and hearth.

The appliance can be installed to a fireplace incorporating a metal flue box complying with the constructional requirements of the current edition of BS 715 and with a flue conforming to BS EN 1856 part 1. The dimensions of the flue box must conform to those shown in figure 8.

The top, sides and rear surface of the metal flue box must be covered with a 50mm layer of mineral wool or equivalent insulation (See figure 8).

Important Note: Where the flue box has a base sheet that is single wall (i.e. a single metal sheet) the flue box must be mounted on a non-combustible hearth. The hearth material must be at least 12mm thick.

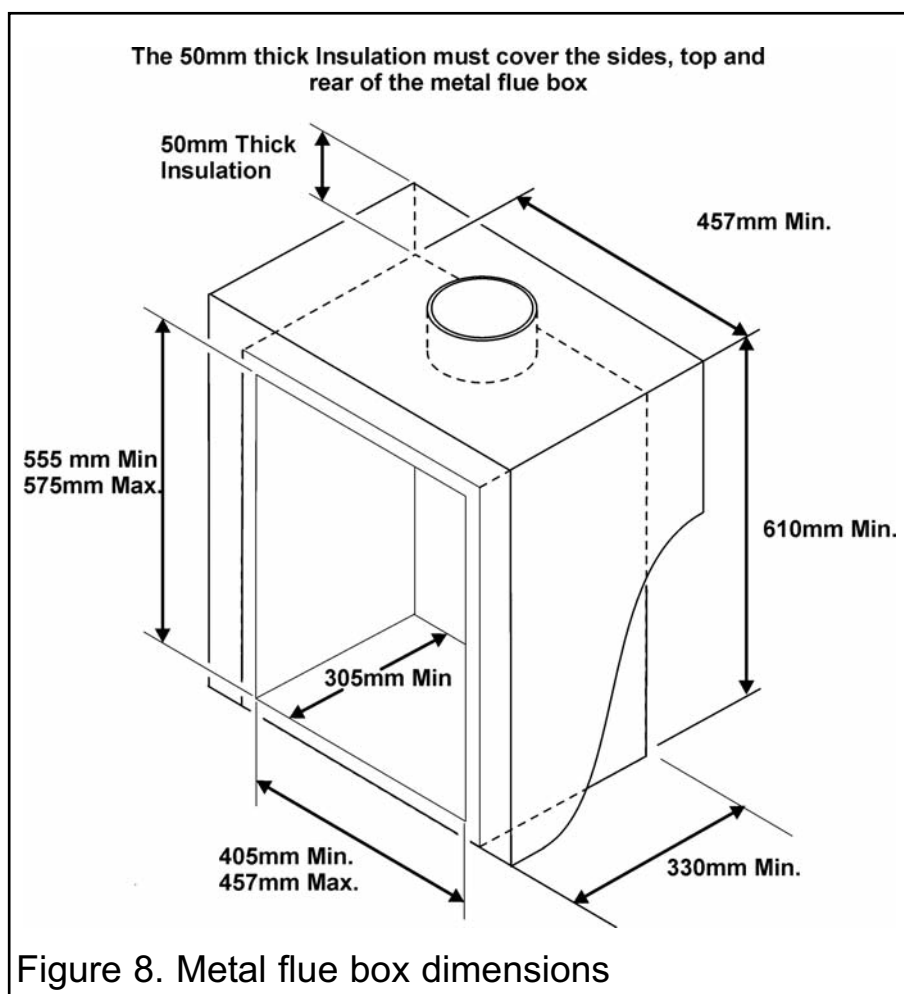

INSTALLER GUIDE

4.10.3 Precast concrete or clay flue block system and hearth.

The appliance can be installed to a precast concrete or clay flue block system conforming to BS EN 1858 with dimensions as in figure 9.

BS 1289 part 1 recommends there should be an air space or insulation between the flue blocks and the plaster because heat transfer may cause cracking on directly plastered flues. However, generally this appliance is suitable for installations under all circumstances unless there is a history of cracking problems.

Remember that faults such as cracking may be caused by poorly built and restrictive flues, e.g. mortar extrusions, too many bends, flue heights below three metres, restrictive terminations etc.

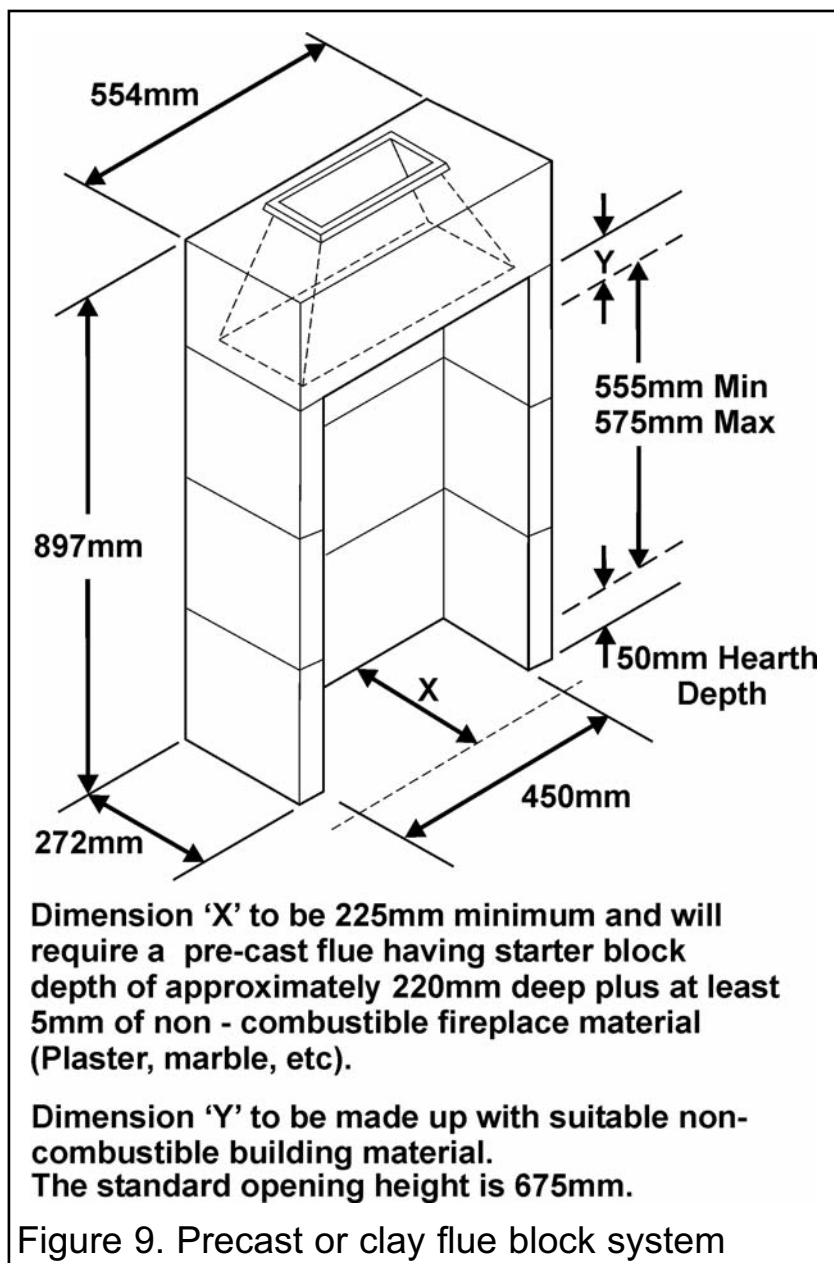

4.11 Flues.

1. Suitable flues and minimum flue sizes are as follows:

It should be noted that, as with many appliances, sharp bends or horizontal runs in metal flues at the top of the system can be a cause of problems in these types of installation.

- 225mm x 225mm conventional brick flue.
- 125mm or 175mm diameter lined brick or stone flue.
- 200mm diameter factory made insulated flue manufactured to BS4543 Part 2.
- 175mm diameter flue pipe. See BS6461 Part 1 for suitable materials.
- Single wall, twin wall or flexible flue liner with a minimum diameter of 125mm. The materials to be used are stainless steel or aluminium as specified in BS EN 1856 Part 1. The liner must be sealed to the surrounding area above the fireplace opening and to the top of the chimney. An approved terminal must be fitted.
- A properly constructed precast concrete or clay flue system conforming to BS1289 or BS EN 1858. This system is only suitable if the conditions stated in section 4.10.3 are met.

2. The flue must conform to BS 5440: Part 1 in design and installation.

The flue, measured from the bottom of the fireplace opening to the bottom of the terminal, shall be not less than 3m in actual vertical height. When calculated in accordance with BS 5440: Part 1 Annex A, the minimum **equivalent** height of the flue shall be 2.0m of 125mm dia. flue pipe.

3. The flue must not be used for any other appliance or application.

4. Proprietary terminals must comply with BS 715 or BS 1289. Any terminal or termination must be positioned in accordance with BS 5440 Part 1 to ensure that the products of combustion can be safely dispersed into the outside atmosphere. Where the appliance is connected to an unlined brick chimney it is generally unnecessary for the chimney pot to be replaced or for a terminal to be fitted unless the flue has a diameter smaller than 170mm.

INSTALLER GUIDE

5. PACK CONTENTS

- 1 Burner and convection box unit.
- 1 Burner tray trim.
- 1 Outlet baffle for the convected air outlet.
- 2 Tapping Screws for outlet baffle.
- 1 Nut and olive for 8mm inlet pipe.
- 1 'T' connector and pressure test point.
- 1 Flue restrictor.
- 3 Tapping Screws (For flue restrictor).
- 2 Small "U" seals (For convection box side flanges).
- 2 Strips of floor sealing tape.
- 6 Fibre / wooden plugs.
- 4 Woodscrews.
- 2 Fire retaining cables.
- 2 Cable clamps.
- 4 Eyebolts.
- 1 Rubber grommet (For rear of convector box).
- 2 Knurled screws (For fascia hanging on Bloomsbury and Ebony models).
- 2 Machine screws (For fascia hanging on Bauhaus models).
- 2 Washers (For fascia hanging on Bauhaus models).
- 1 PP3 Alkaline battery.
- 1 Smoke match tube.
- 2 Fireback spacing brackets.
- 4 Tapping Screws (For fireback spacing brackets).
- 1 Length of self adhesive foam seal.
- 1 Literature pack (Not shown).
- 1 Ceramic fuel effect set (Not shown).
- 1 Slider control position label.
- 1 Control knob extension bracket (Bloomsbury only)
- 2 M4 x 7mm screws for securing the control knob extension bracket (Bloomsbury only).
- 1 Fascia and firefront casting.
- 1 Fascia Hood (Bauhaus and Ebony only).
- 4 Screws for fascia hood (Bauhaus and Ebony only).

Carefully remove all the contents. Take special care in handling the ceramic pieces. Take care not to bend or distort the slide control linkage. Check that all the listed parts are present and in good condition.

INSTALLER GUIDE

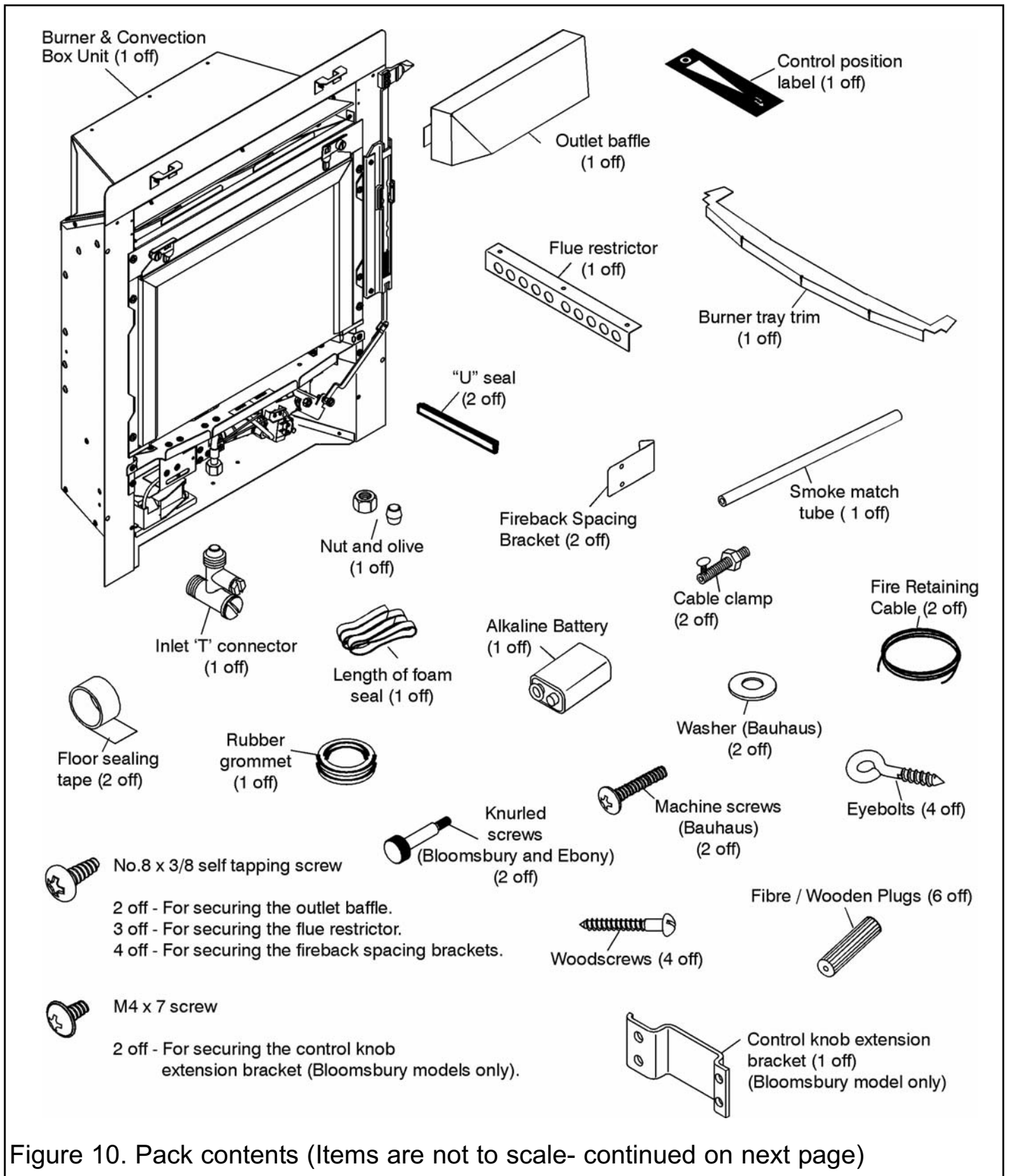
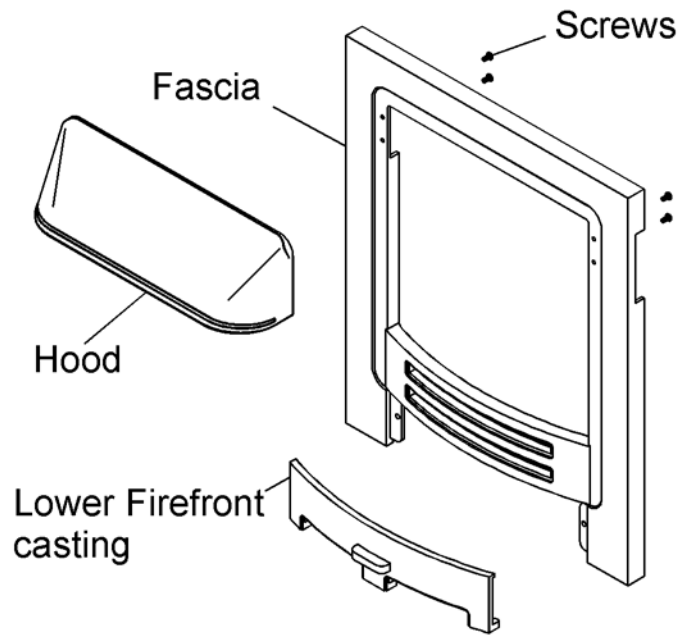

Figure 10. Pack contents (Items are not to scale- continued on next page)

INSTALLER GUIDE

Ebony Fascia.



Bloomsbury Fascia.

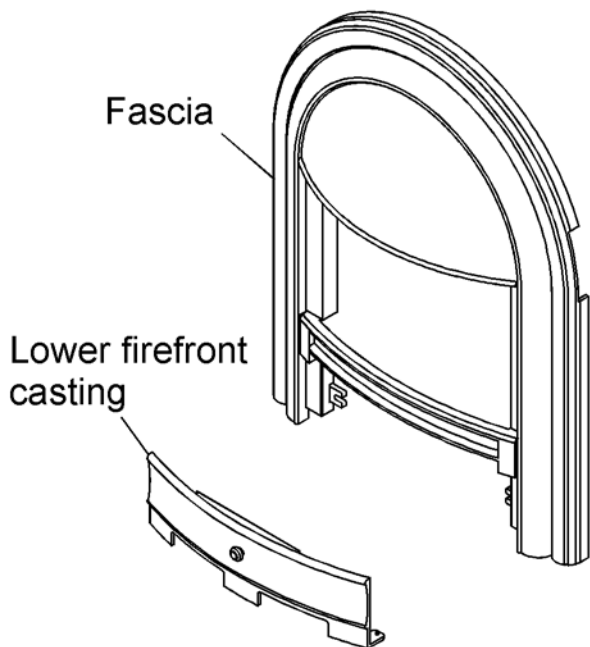

Bauhaus Fascia.

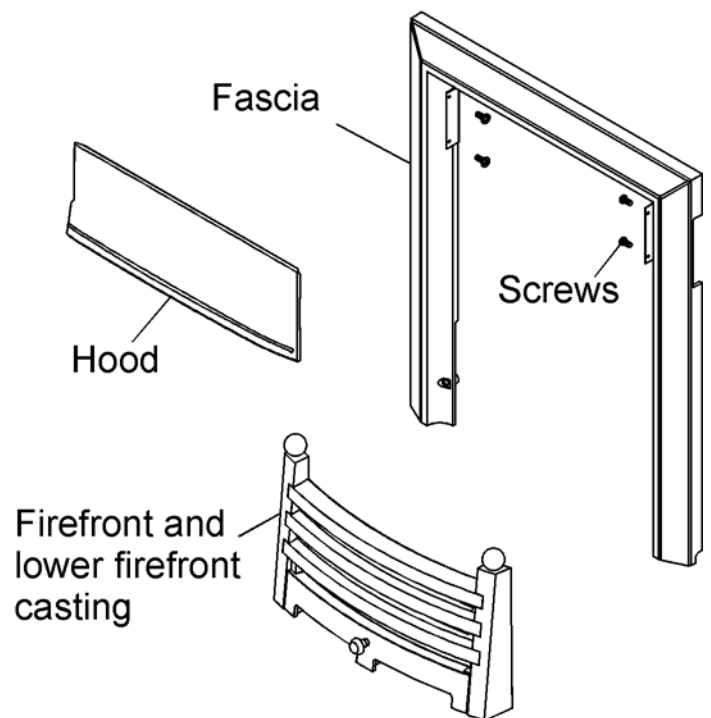

Figure 10. Pack contents continued (Items are not to scale)

6.1 Soundness for appliance attachment.

Two primary methods of retaining the appliance are provided: -

- 1) By fixing to the fireplace front surround.
- 2) Using concealed tension cables fixed to the rear of the fireplace opening together with secondary fixing to the fireplace floor.

The methods are detailed in section 10 of this guide. Before selecting the retention method, consult with the customer. Method 2 is provided for instances where drilling holes in the front surface of the fireplace surround is unacceptable to the customer or otherwise impractical. *N.B. It is unwise to attempt to drill into marble without the proper tools and equipment.*

If method 1 is chosen, make sure that the front surround area is sound enough to take the fibre / wooden plugs and woodscrews. If necessary, make sound with suitable cement.

If method 2 is chosen, make sure that the areas at the back and towards the centre of the fireplace floor are sound enough to take the eyebolts and screws. If these areas have deteriorated due to prolonged use, they should be made sound with suitable cement.

6.2 Fireplace flue pull.

Close all doors and windows in the room in which the appliance is to be installed. After confirming with a match that smoke is drawn into the flue, light a 13 gram smoke pellet and check that there is a definite flow through the flue. Verify outside that the smoke exits from one terminal only and that the termination is suitable. Observe, where possible, upstairs rooms and loft spaces for signs of escaping smoke indicating a defective flue. If there is not a definite flow warm the flue for a few minutes and repeat the smoke pellet test. If there is still no definite flow the flue may need remedial work – **Do not fit the appliance until there is a definite flow through the flue.**

INSTALLER GUIDE

7. IGNITION CHECK

Before attempting to install, it is worth checking that the electronic ignition system performs satisfactorily. Fit the alkaline battery to the ignition block located below the burner tray at the left side (See figure 11). The positive terminal (+) is to the bottom as you insert.

Depress the slider knob as far as it will go and hold in this position. This should close the ignition circuit and sparks should be seen tracking from the electrode pin to the pilot tip (See figure 12).

If there are no sparks make the following checks.

- Check condition of alkaline battery and that it is correctly fitted.
- If the above is satisfactory, check the ignition circuit and components - see the servicing section in this guide.

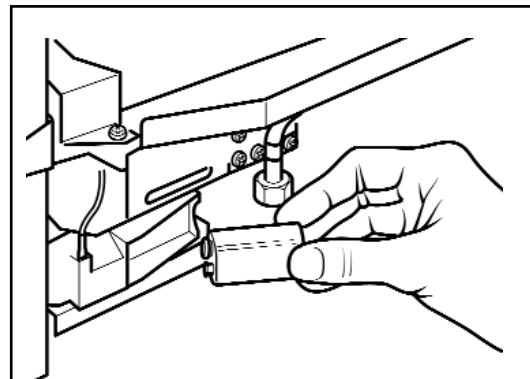

Figure 11. Fitting the alkaline battery

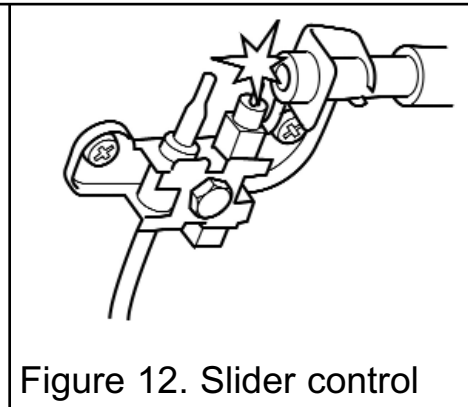

Figure 12. Slider control

8. GAS SUPPLY CONNECTION

A nut and olive are provided for an 8mm pipe inlet connection to the 'T' connector at the bottom front of the appliance. The 'T' connector can be rotated to allow a connection from any direction and includes a valve for isolating the gas supply and a pressure test point.

The supply pipe must be rigid material. Flexible pipe must not be used.

Concealed Supply Pipe Connection

If a concealed connection from inside the fireplace is required then, **before the appliance is fitted into the fireplace** it will be necessary to extend the supply line so that it will project through the hole in the back of the convection box and run to the 'T' connector at the front. The pipe run from the supply line up to the rear opening in the convection box must be kept away from the area which will be taken by the convection box when it is installed (See figure 7).

Note that the centre of the appliance inlet 'T' connector is 25mm above the fireplace floor. The inlet 'T' connector should be fitted to the supply pipe at this stage.

INSTALLER GUIDE

9. PREPARING APPLIANCE FOR INSTALLATION

1. Unscrew and remove the knurled screw connecting the slider control arm to the burner module. Lift the slider control knob, moving the control arm away from the burner module.

2. Unscrew and remove the six screws that secure the window mounting frame and window assembly. Remove and place away from the work area (See figure 13).

3. Detach the burner unit from the convection box by removing two screws (See figure 14). Lift the burner unit clear.

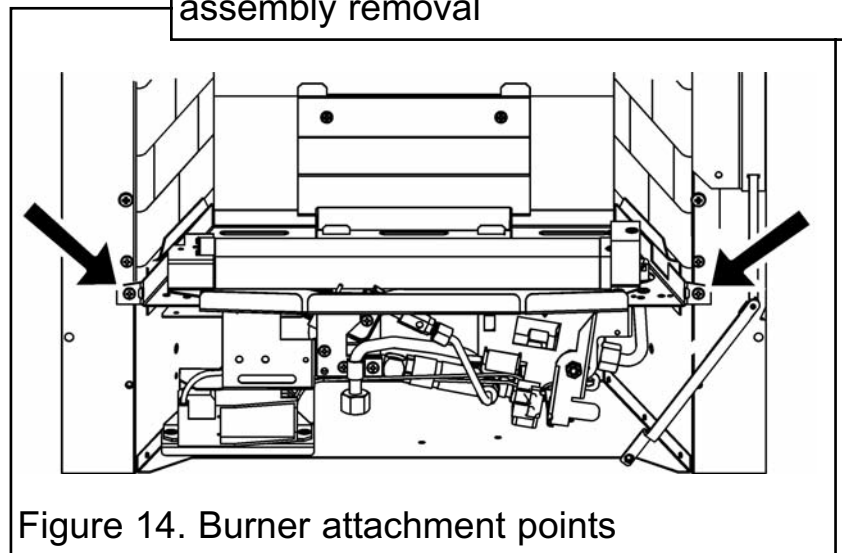
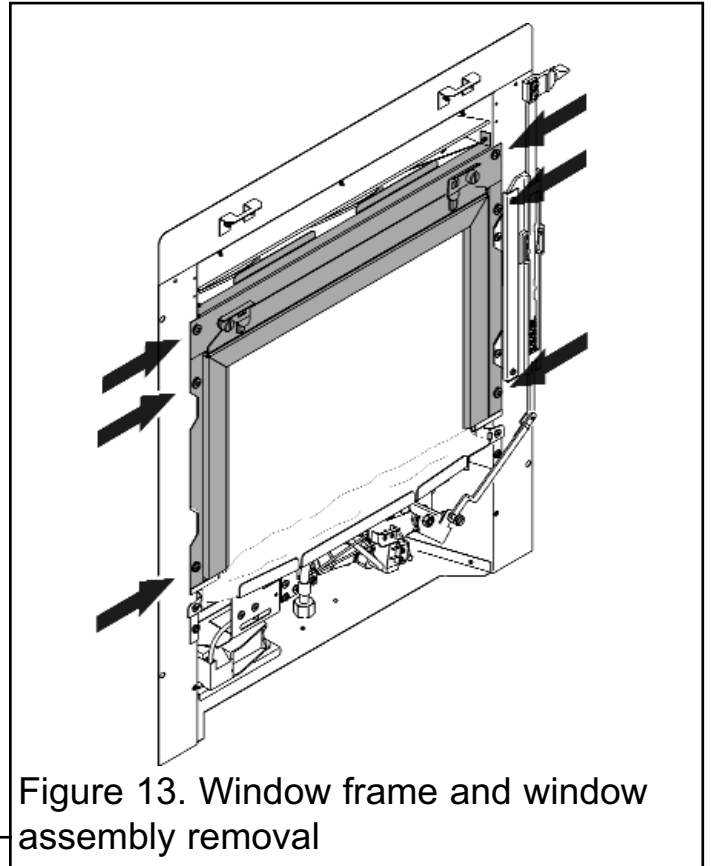

INSTALLER GUIDE

4. Fit the two “U” section seals to the bottom edges of the convection box side flanges (See figure 15).

5. It is important that the grommet supplied in the loose parts pack is fitted to the hole in the rear of the convection box (See figure 18).

For concealed connection only:

Pierce the grommet to allow the pipe to pass through it. The grommet should envelop the pipe. If the hole is larger than the pipe, seal it with tape. Do not pierce the grommet unless the supply pipe is to pass through it.

6. The appliance is supplied with two fireback spacers that must be fitted in all installations. These should extend backwards to ensure sufficient clearance from the back of the fireplace. Position the fireback spacer as shown in figure 16. Secure the fireback spacers using the four tapping screws supplied with the fire.

7. This appliance is supplied with a flue restrictor for use where the flue draught is excessive. Generally we recommend the restrictor is NOT fitted where a precast flue, metal flue box or a flue liner is used, however, certain flues may work sufficiently to warrant its use. There may however, be circumstances where fitting the restrictor causes the fire to fail the spillage test. In such cases the restrictor will have to be removed. After removal conduct the spillage check again.

The restrictor is packed loose with the appliance and is fixed with three screws (See figure 17).

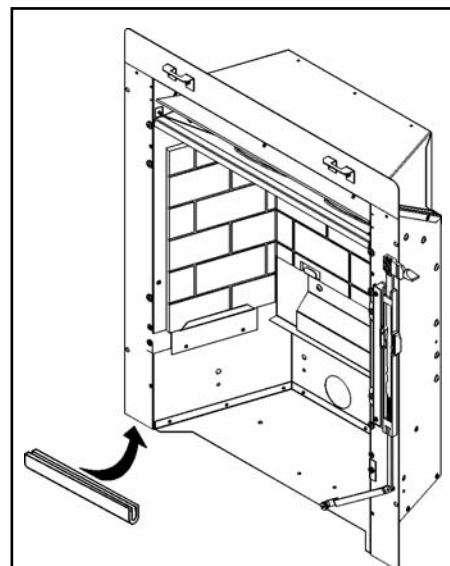

Figure 15. 'U' Seals

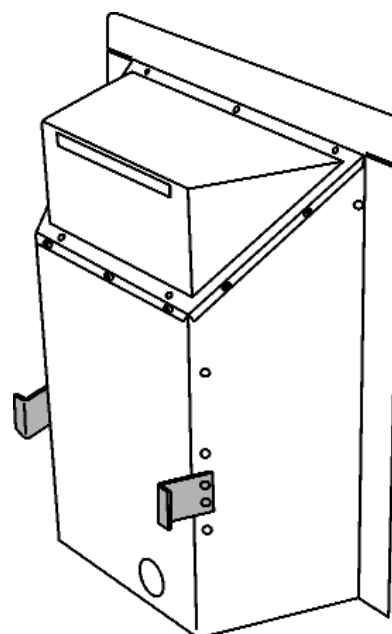

Figure 16. Fireback spacers.

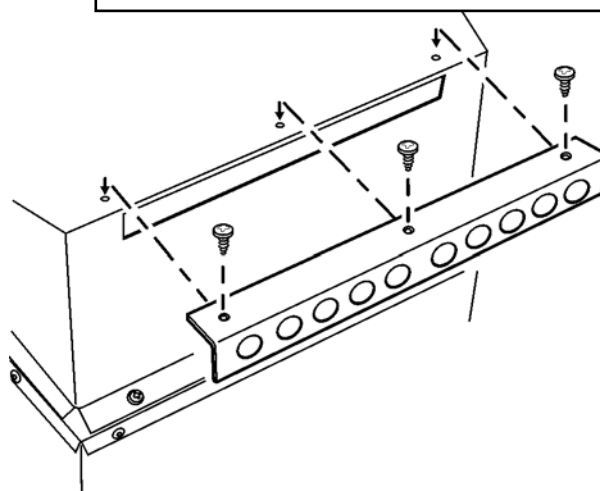

Figure 17. Flue restrictor

INSTALLER GUIDE

8. There is a length of self adhesive foam seal supplied with the fire. This will need to be fitted to the outer rear edges of the side and top flanges of the convector box. Cut a 485mm length of foam seal. Be careful not to stretch the seal when measuring. Remove the protective backing from the foam seal and fit this to the rear of the top flange (See figure 18). Cut two 580mm lengths. Fit these to the rear outer edges of the side flanges. Ensure that there is no gap between the foam seals where they meet at the top flange (See figure 18).

The foam seal should touch at this point. Ensure that there is no gap between the seals.

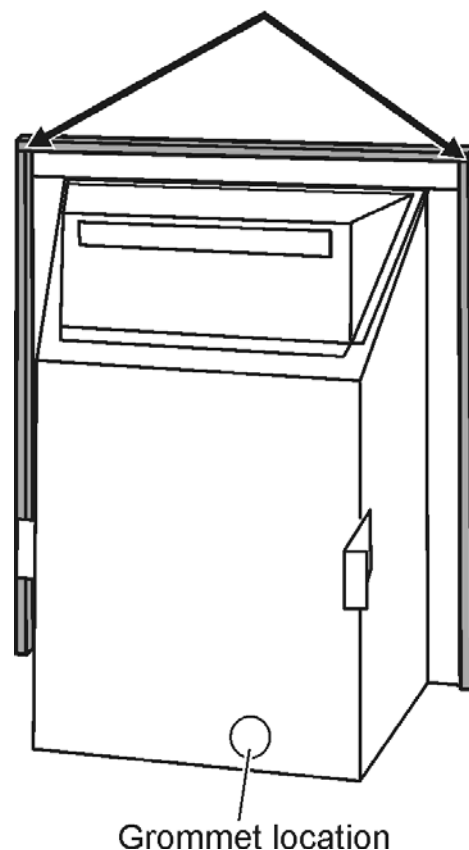

Figure 18. Fitting the foam seal

10. CONVECTION BOX INSTALLATION

10.1 Method 1 - Front fixing to fireplace surround.

1. Make sure that the fireplace front surround area is sound enough to take the fibre / wooden plugs and woodscrews. If necessary, make sound with suitable cement.

2. Place the convection box centrally in the fireplace in the position in which it is to be permanently installed. If a concealed connection is being used, insert the convection box into the fireplace feeding the supply pipe through the pierced hole in the rear grommet.

3. Mark the fireplace front surround through the four fixing holes in the side flanges of the convection box (See figure 19).

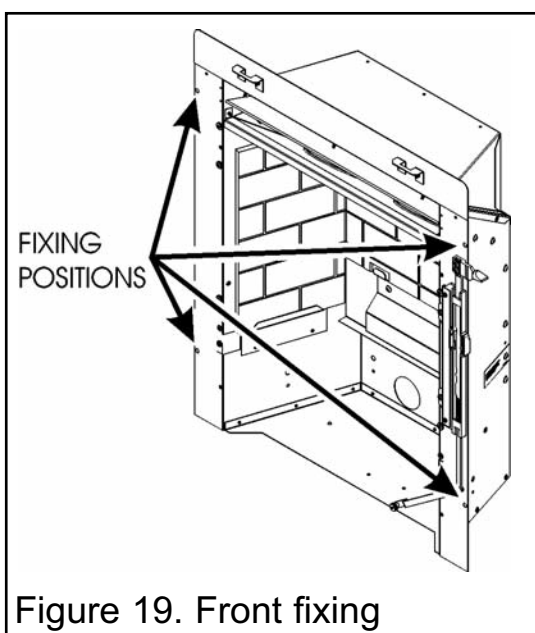

Figure 19. Front fixing

INSTALLER GUIDE

4. Remove the convection box. Drill four holes in the fireplace front surround at the marked positions using a suitably sized masonry drill for the fibre / wooden plugs supplied.
5. Insert a fibre / wooden plug into each hole.
6. Place the convection box back in position in the fireplace.
7. Fit a woodscrew through each hole in the convection box flanges and tighten to seal the box to the fireplace surround.

10.2 Method 2 - Cable retention and floor fixing.

1. Make sure that the relevant areas at the fireplace back or floor are sound enough to take the eyebolts and screws. If these areas have deteriorated due to prolonged use they should be made sound with suitable cement.

2. Drill four holes in the rear wall of the fireplace for the eyebolt plugs. The holes should be drilled within the range of positions shown in figure 20 using a suitably sized masonry drill for the fibre / wooden plugs supplied. The holes should be equidistant each side of the

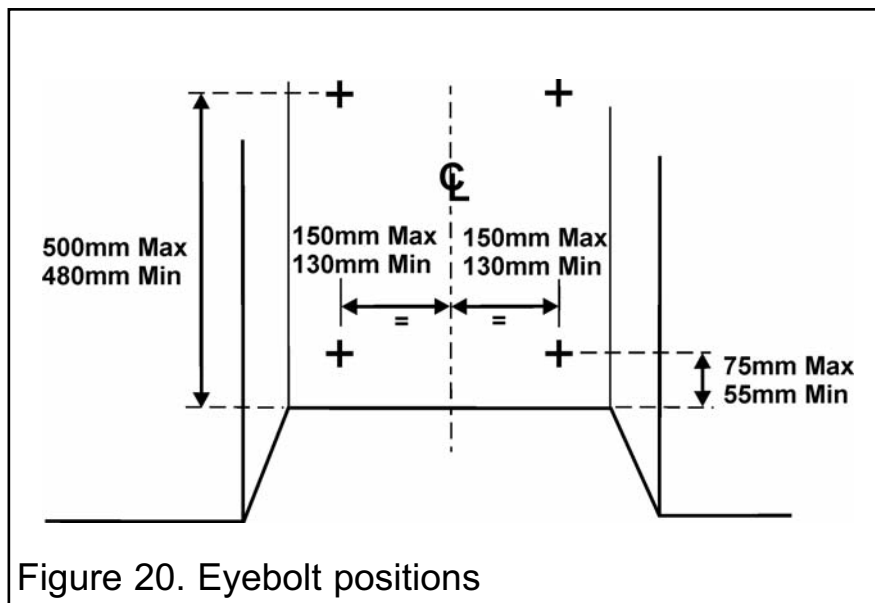

centre line of the fireplace to ensure that the appliance finishes centrally in the opening when tension is applied to the cables.

3. Insert a fibre / wooden plug into each hole. Use the fibre / wooden plugs supplied with this appliance - **Never use plastic plugs instead of the fibre / wooden plugs supplied.** Screw the eyebolts into the plugs. Make sure that the bolts are secure.

4. Place the convection box unit close to the fireplace but allow sufficient access into the fireplace opening so that the cables can be threaded through the

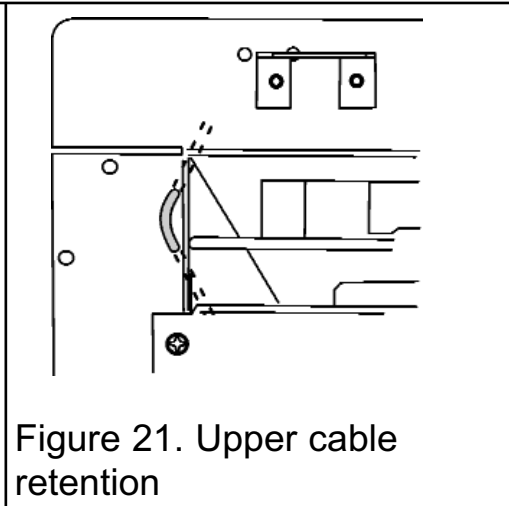

eyebolts and returned through the back of the convection box. If a concealed connection is being used, insert the convection box into the fireplace feeding the supply pipe through the pierced hole in the rear grommet.

5. The convection box has two holes at each side of the convected air opening. Insert one end of each cable (one cable each side) from the back through the lower of the two holes and return the end through the upper of the holes (See figure 21). Give the cables a pull so that they grip against the convection box flanges.

INSTALLER GUIDE

6. Thread the cables through the eyebolts. Return the cables through the holes near the bottom of the convection box back panel (See figure 22).

7. Place the convection box fully back into the fireplace opening so that it is sealed against the fireplace front surround.

8. Drill a hole into the fireplace floor through each of the two holes in the base of the convection box using a suitably sized masonry drill for the fibre / wooden plugs supplied (See figure 23).

9. Insert a fibre / wooden plug into each hole. Use the fibre / wooden plugs supplied with this appliance - **Never use plastic plugs instead of the fibre / wooden plugs supplied.** Fit a woodscrew in each plug and tighten. Always screw the base into position before applying tension to the cables. This will ensure a tight seal between the top of the convection box and wall.

10. Fit a cable retainer over the bottom end of each cable.

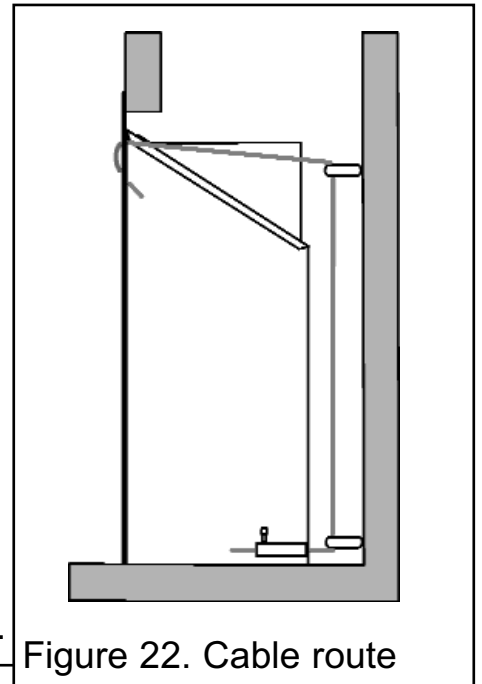

Figure 22. Cable route

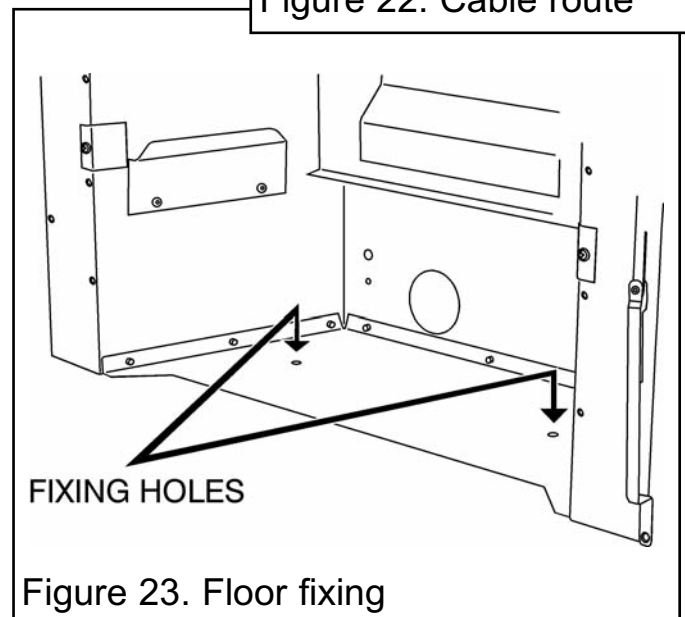

Figure 23. Floor fixing

INSTALLER GUIDE

11. Pull each cable taut. Push the cable retainers hard up against the back panel. The end of the cable adjuster will pass into the hole. Tighten the screws in the retainers so that they clamp the cables in position. Apply tension to the cables by turning the hexagonal adjusters by hand (See figure 24).

12. Inspect the installation of the convection box against the fireplace surround. If the convection box is aligned squarely and the sealing is satisfactory, fully tighten the cable retainers.

13. If the convection box is not correctly aligned, release the tension on the cables by slackening the screws and turning the hexagonal adjusters fully anticlockwise. The convection box should then automatically realign itself. Pull each cable taut again and push the cable retainers back against the back panel. Again, tighten the screws in the retainers and apply tension to the cables by turning the hexagonal adjusters clockwise as far as possible.

14. Feed the free length of the cables into the gap between the inner and outer back panels so that they are available to allow easy removal and refitting of the appliance during subsequent service calls. **Do not cut off the free lengths of cable** (See figure 24).

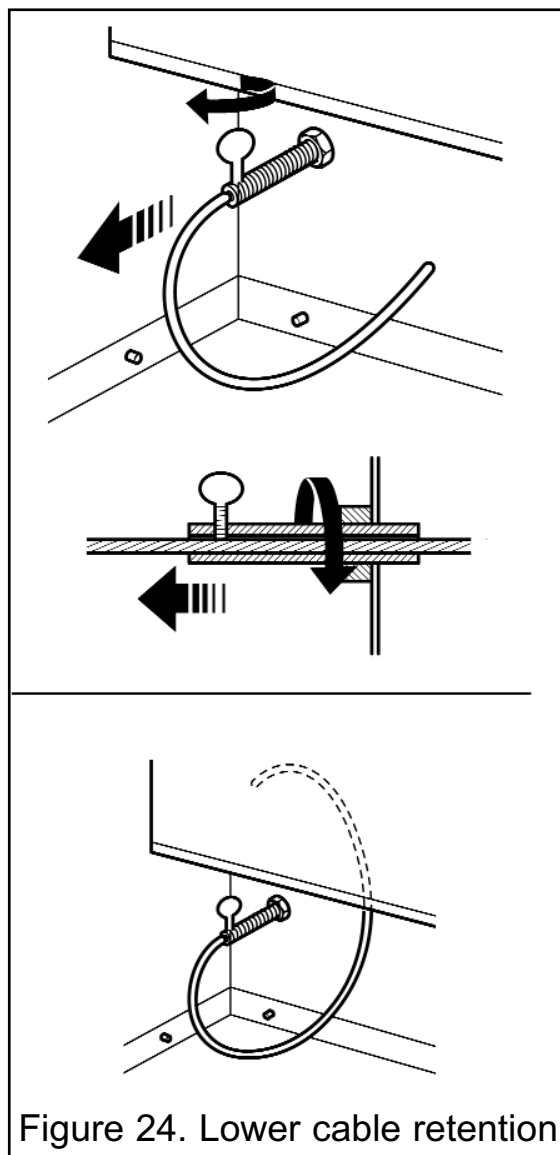

10.3 Sealing floor front - All installations.

Using the floor sealing tape supplied, seal the bottom of the convection box to the fireplace and hearth floor (See figure 25).

Make sure that the whole length of the front edge of the convection box is fully sealed.

10.4 Sealing convection box holes.

The rear and inner sides of the convection box have small holes / openings that will allow room air to pass into the fireplace opening / flue box opening. Although these holes are no cause for concern it is important to seal them to optimise the performance of the fire. An additional length of tape is supplied with the fire, use this to seal any holes in the rear and inner sides of the convection box. **DO NOT** tape over the large holes in the top of the convection box.

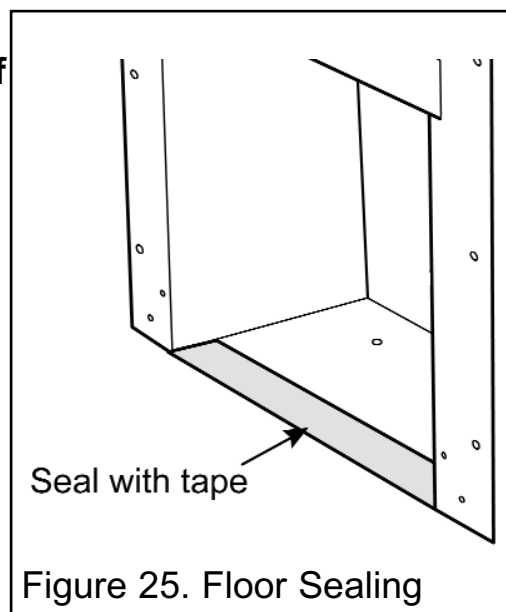

1 1. BURNER AND SUPPLY PIPE INSTALLATION

11.1 Burner and supply pipe installation.

1. Refit the burner unit to the convection box with the two screws removed previously.
2. Connect the supply line to the appliance.
3. If closed, open the isolating valve at the inlet 'T' connector.
4. Turn on the gas supply and pressure check the installation pipework for gas soundness. In the United Kingdom (GB) check in accordance with the current edition of BS 6891. In the Republic of Ireland check in accordance with the current edition of IS 813 "Domestic Gas Installations".

11.2 Preliminary burner checks.

Some burner operations can be checked at this stage. Checking now will mean that less disassembly will be required if any problems are found. **A full check should still be made, however, after final installation.**

1. Rotate the control pivot bracket clockwise as far as it will go and hold in this position (See figure 26). This should close the ignition circuit and simultaneously open the gas tap allowing the gas to flow to the pilot. Wait a few seconds while the air is purged. The electronically generated sparks should light the pilot. The pilot should then light the main burner at its low setting. There may be a delay of up to four seconds between the pilot lighting and ignition of the gas at the main burner. This is normal and is due to the time required to fill the main burner compartment with sufficient gas for ignition.

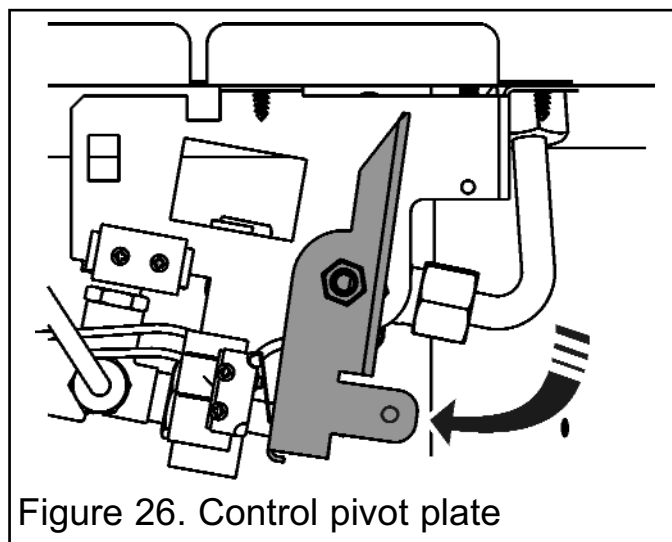

Figure 26. Control pivot plate

2. When the burner is operating properly, gradually turn the control pivot bracket anti-clockwise. The burner flames should gradually increase until the pivot bracket is nearly at its furthest anti-clockwise rotation. Rotating further until the pivot bracket comes to a stop should then turn the burner and pilot off.
3. If the above checks are satisfactory, continue with the installation. If not, check the control and ignition circuitry and components as described in the servicing section of this guide.
4. Align the hole near the bottom of the control linking bar with that in the control pivot bracket. Join them with the knurled shouldered screw removed previously (Use a screwdriver - do not leave as finger tight only).

INSTALLER GUIDE

11.3 Inlet pressure check.

The appliance is pre-set to give the correct heat input at the inlet pressure shown in section 3 of this guide. No adjustment is necessary.

1. Ensure that the appliance is OFF, then fit a pressure gauge at the test point (See figure 27).
2. Check the pressure with the appliance alight and set at maximum output.
3. After checking, turn off the appliance. Remove the pressure gauge and replace the test point sealing screw.
4. Test around the sealing screw and end cap for gas soundness with a suitable leak detection fluid.
5. Fit the burner baffle to the front flanges of the burner. To do this, locate the tags on the baffle over the front flanges of the burner and lower into position (See figure 28).
6. It is advisable at this stage to remove the alkaline battery to avoid accidental ignition whilst fitting the ceramic fuel effect.

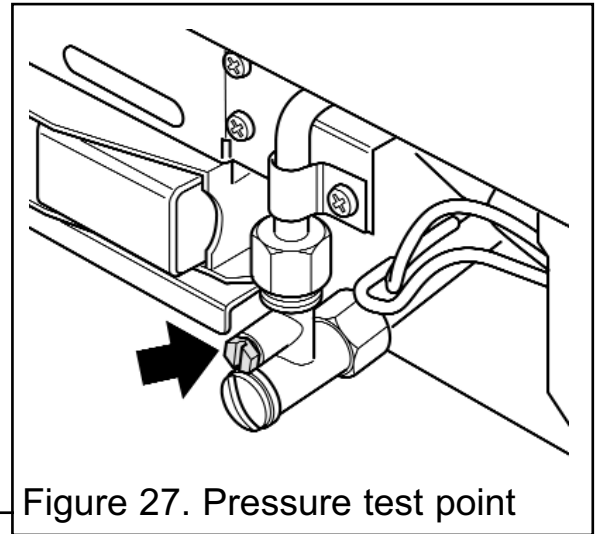

Figure 27. Pressure test point

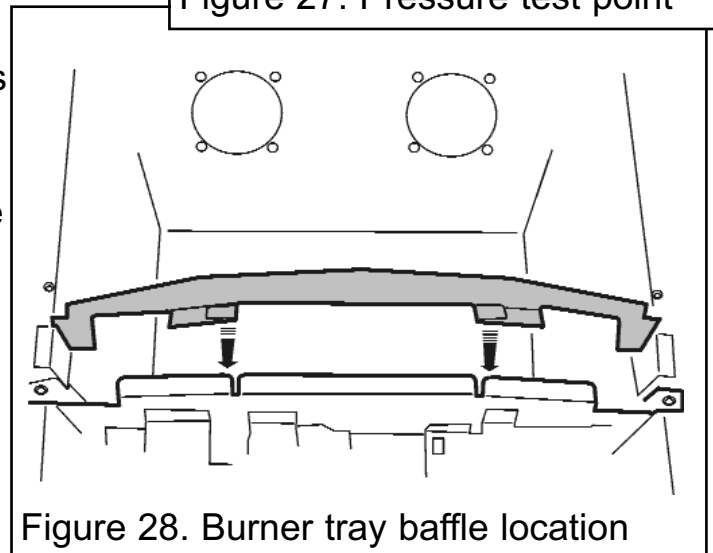

Figure 28. Burner tray baffle location

12. FITTING THE CERAMIC FUEL EFFECT

The installer and owner guide for the ceramic fuel effect is supplied with the ceramic fuel effect. It is important that the fitting guide for the ceramic fuel effect be placed inside or attached to this guide and handed to the customer following completion of the 'Final review' section.

INSTALLER GUIDE

13. FITTING THE WINDOW FRAME ASSEMBLY

1. Locate the window mounting frame and window assembly in place.
2. Secure in place using the six screws removed previously.

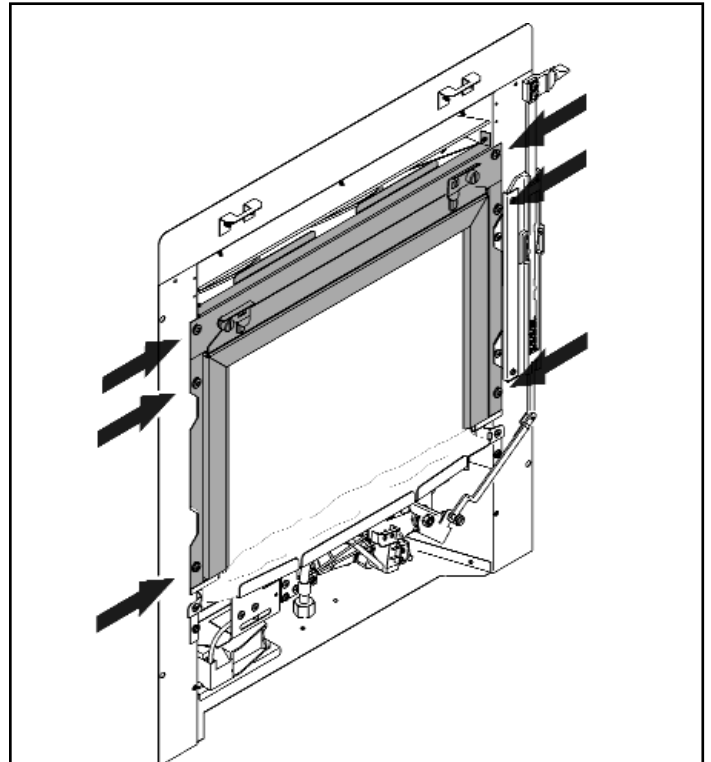

Figure 29. Window mounting frame and window assembly removal

14. OPERATING AND SPILLAGE CHECKS

14.1 Fitting the control knob extension bracket on the Bloomsbury model.

1. Unscrew and remove the two screws that connect the control knob to the top of the slider mechanism. Place the control knob and screws aside.
2. Fit the control knob extension bracket as in figure 30 using the two M4 x 7mm screws supplied.
3. Fit the control knob to the extension bracket using the two screws removed previously (See figure 30).

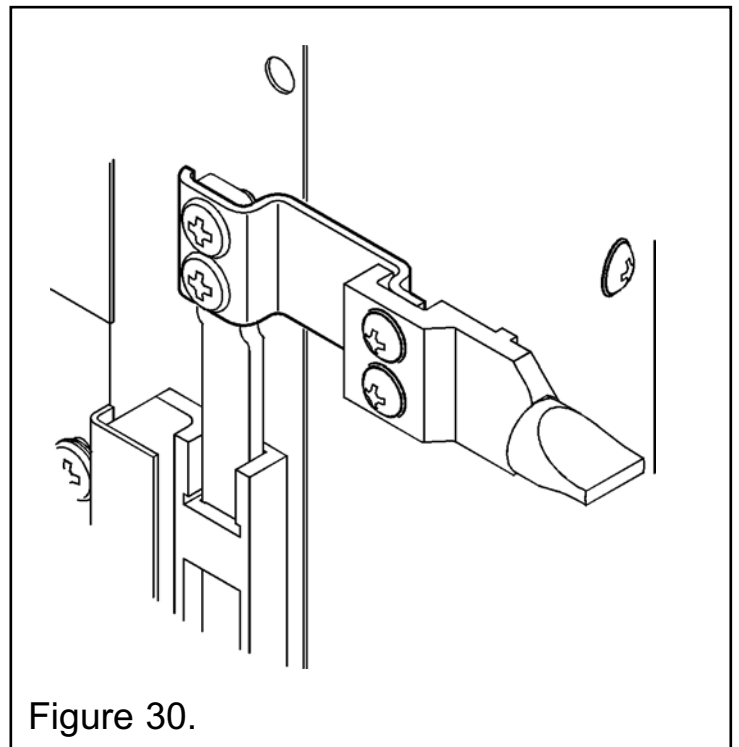

Figure 30.

INSTALLER GUIDE

14.2 Checking the control settings.

Please note:

- *When first turned on from cold, the flames will appear predominantly blue. It is normal for condensation to form on the rear of the window assembly. The condensation will disappear after a few minutes use.*
- *When operating the fire for the first time, some vapours may be given off which could set off smoke alarms in the vicinity. These vapours are quite normal with new appliances. They are totally harmless and will disappear after a few hours use.*

1. Fit the alkaline battery if previously removed.
2. Make sure the slider button is at the off position (At topmost position).
3. Slide the button to the bottom (ignition) position. Retain in this position to ignite the pilot. The burner should ignite at its lowest setting within 4 seconds of the pilot igniting. Keep at this position for a further 10 seconds to allow the pilot flame to stabilise.
4. Release the button. The button should automatically spring up to the low heat position. If for any reason the slider control does not spring up, raise the slider to the topmost (Off) position and investigate why the slider is not operating correctly. If the flames go out at this stage or when checking the rest of the setting positions, try the full lighting sequence again. If the flames fail after two attempts, investigate the pilot unit.
5. Gradually slide the button up to increase the burner setting. You should feel a check to the button movement at this position.
6. Slide the control button up past the high heat position to the topmost (Off) position. Both pilot and main burner should go out. While cooling the ceramic fuel effect may make some crackling noises. This is quite normal.

14.3 Check for spillage.

A spillage check must be made before leaving the installed appliance with the customer.

1. Close all doors and windows in the room containing the appliance.
2. Light the appliance and set the slide control to the maximum burning position.
3. Leave the appliance on for five minutes.
4. The smoke match should be placed horizontally into the top of the down draught air relief opening, 70mm from the right hand side. Insert the smoke match tube up to the neck of its flared end (approximately 20mm) (See figure 31).

The installation is satisfactory if the smoke is drawn into the appliance. Under clearance conditions smoke may be seen to swirl in the opening and small quantities may occasionally escape. The majority of smoke should be clearly drawn into the appliance.

If the smoke is not drawn into the appliance leave the appliance alight at the maximum setting for a further ten minutes and then repeat the test. If the smoke is still

not drawn into the appliance inspect the sealing to the fireplace surround. If the sealing is satisfactory but the appliance is installed with the flue restrictor (See section 9 point 7) remove the restrictor, reseal the appliance and retest. If smoke is still not drawn into the appliance

disconnect the appliance and seek expert advice.

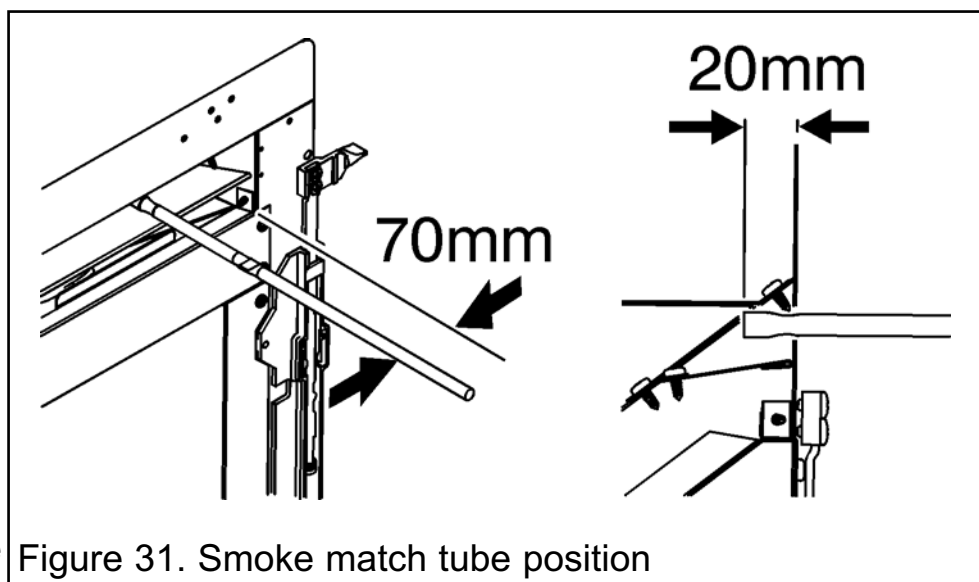

Figure 31. Smoke match tube position

5. If the above test is satisfactory open all internal connecting doors, hatches, etc. in the room. Keep all doors and windows that open to the outside of the building closed. Recheck for spillage as above. If an extractor fan is installed in the same room as the appliance or a connecting room, check that spillage does not occur with the fan operating and all doors and other openings between the fan and the appliance open. If the smoke is drawn into the appliance, continue with the installation. If the test is not satisfactory **disconnect the appliance and advise the customer of the cause of failure.**

14.4 Flame supervision and spillage monitoring system.

This pilot unit includes a system that will automatically shut off the gas supply if the pilot flame goes out or if there is insufficient oxygen due to spillage or poor ventilation. Check that the system operates properly as follows;

- 1.** Light the appliance. Set the slide control to the maximum burning position (This can be found by sliding the control knob up until a check to the slider movement is felt) and leave for one minute.
- 2.** Set the control to the 'Low' burning position. Isolate the gas supply at the inlet 'T' connector. The pilot and main burner will go out. **Note the time when the pilot goes out.** Listen for a snap sound at the gas tap. **Note the time when the sound is heard.** This sound is caused by an electromagnetic valve shutting off the gas supply through the tap. The valve is located in the body of the tap. The valve should operate **within 60 seconds of the pilot going out.** If the valve does not operate within this time limit do not allow the appliance to be used until the fault has been corrected. **This monitoring system must not be adjusted, bypassed or put out of operation. This monitoring system, or any of its parts, must only be exchanged using authorised parts.**
- 3.** Open the isolating valve on the inlet 'T' connector. Screw on the end cap and test for leaks.
- 4.** Set the slider to the topmost (Off) position.

15. OUTLET BAFFLE AND FASCIA FITTING

15.1 Fitting the outlet baffle.

Locate the outlet baffle and secure in place using two tapping screws supplied (See figure 32).

Before fitting the fascia ensure that the information on the back pages of the owner guide have been completed.

Please remove all protective film and packaging before fitting the fascia.

15.2 Fitting the fascia.

1. Supplied with the fire is a self adhesive control position label. Peel the backing from the label and place as in figure 33.
2. Place the fascia against the fireplace front surface so that the two retaining plates at the back of the fascia are above the two upper retaining brackets at the top of the convection box. Lower the fascia making sure that the rear retaining plates locate fully into the retaining brackets on the convection box (See figure 33). If the inlet pipe runs along the front of the fireplace, the bottom of the fascia will have to be swung forwards to clear the pipe while lowering the casting.

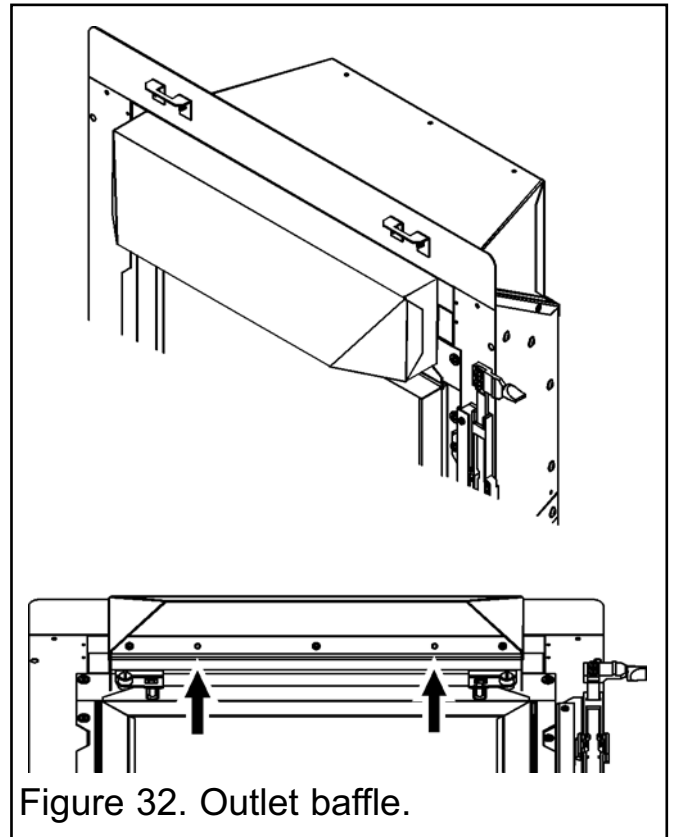

Figure 32. Outlet baffle.

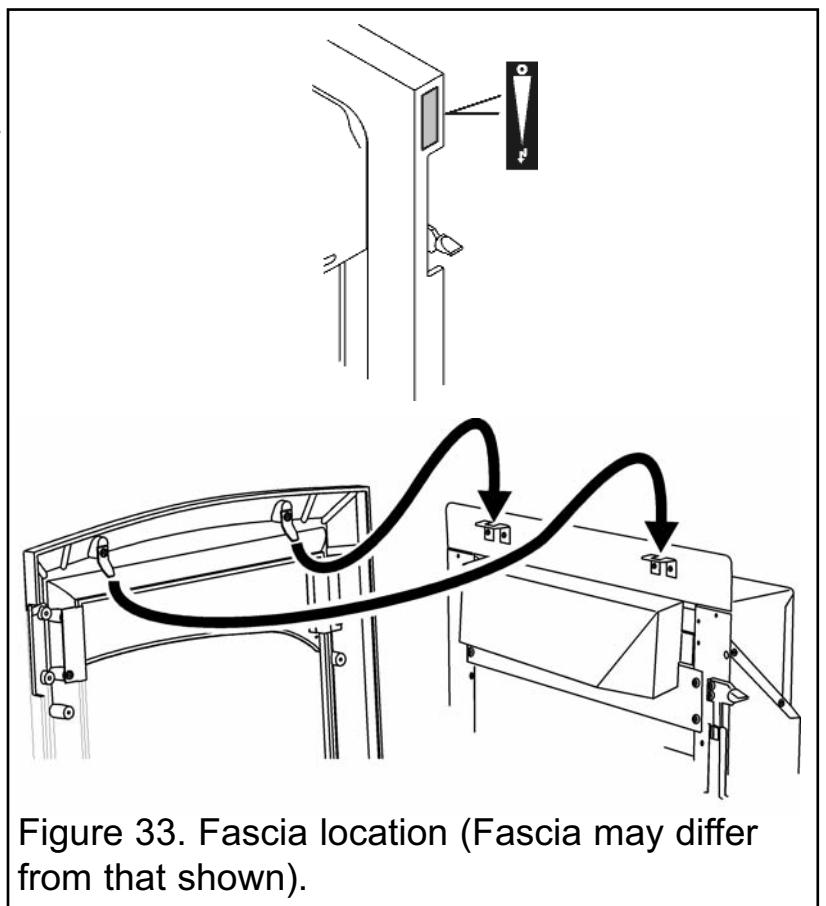
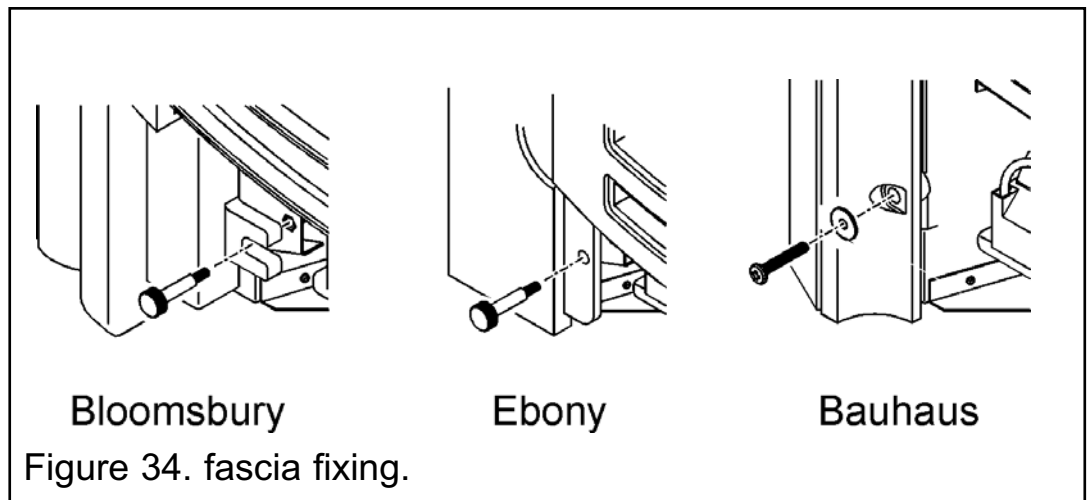

Figure 33. Fascia location (Fascia may differ from that shown).

INSTALLER GUIDE

3. For Bloomsbury and Ebony models. Secure the bottom of the fascia using two knurled screws (See figure 34). Please note that on Bloomsbury and Ebony models that the casting is not expected to sit flat against the fixing bracket. Tighten the knurled screws sufficiently to retain the casting, over tightening the screws will cause damage.

3. For Bauhaus models. Secure the bottom of the fascia using the two machine screws and washers supplied (See figure 34). Tighten the screws sufficiently to retain the casting, over tightening the screws will cause damage.



15.3 Fitting the firefront casting / lower firefront casting.

1. Place the firefront casting / lower firefront casting in place.

- 1. COMPLETE THE INFORMATION IN THE WARRANTY AND SERVICE SECTION OF THE OWNER GUIDE (See last pages of the OWNER guide).**
2. Visually inspect the appliance. Clean off any marks incurred during installation.
3. Advise the customer how to operate the appliance. Explain to the customer that the appliance has a flame failure & spillage monitoring system. Point out the explanation of this system shown in the owner guide under “Operating the fire”. Advise that if the fire goes out for any reason, wait at least three minutes before relighting. Stress that if the monitoring system repeatedly shuts off the fire, the appliance should be switched off and a specialist should be consulted.
4. Advise the customer that they should read their owner guide before operating the fire and always follow the advice in the section headed “Cleaning your fire”.
- 5. Stress that no extra ceramic fuel effect pieces must be added over and above those supplied with the appliance and that any replacements must only be the authorised spares. Warn that ignoring this advice could cause incomplete clearance of the products of combustion with consequent health hazards. If you have not done so already; attach or place the ceramic fuel effect guide inside this guide.**
6. Advise the customer that the appliance will operate to its maximum potential if the flue is primed during the first 20 – 30 minutes of use. To do this, simply slide the control to its highest heat setting. This will also burn off any carbon deposits that may have formed during previous use.
- 7. Emphasise that if the window assembly is broken or damaged, the fire should be turned off and not used until the window unit is refitted with an authorised replacement. The fire should not be used without the window assembly fitted.**
8. Advise the customer that when first turned on from cold, the flames will appear predominantly blue and it is normal for condensation to form on the rear of the window assembly. The condensation will disappear after a few minutes use.
9. If using the appliance for long periods it is beneficial to change between settings. This will also help to remove any carbon deposits that may form during use.
10. Recommend that the appliance should be serviced by a competent person at least annually.
11. If the appliance is in premises in the United Kingdom occupied by a tenant, point out that by law a landlord must have any gas appliance, flue and pipework which is situated in a tenant’s premises checked for safety at least every 12 months.
12. Advise that the fire may give off a slight odour while new. This is quite normal and it will disappear after a few hours use.
- 13. Inform the customer that the Serial number for the appliance is located on the information label, located on a chained plate behind the lower front casting and underneath the burner module.**
14. Hand the literature pack with this guide to the customer.

17. SERVICING AND PARTS REPLACEMENT

- Always turn off the gas supply before commencing any servicing and allow to cool completely. (The appliance inlet 'T' connector incorporates an isolating valve).
- It is recommended that, at least once a year, the appliance is disconnected and the fireplace opening checked and cleared of any debris.
- This product uses fuel effect pieces and burner compartment walls containing Refractory Ceramic Fibres (RCF), which are man-made vitreous silicate fibres. Excessive exposure to these materials may cause irritation to eyes, skin and respiratory tract. Consequently, it is important to take care when handling these articles to ensure that the release of dust is kept to a minimum. To ensure that the release of fibres from these RCF articles is kept to a minimum, during installation and servicing we recommend that you use a HEPA filtered vacuum to remove any dust and soot accumulated in and around the fire before and after working on the fire. When replacing these articles we recommend that the replaced items are not broken up, but are sealed within a heavy duty polythene bag, clearly labelled as RCF waste. RCF waste is classed as a stable, non-reactive hazardous waste and may be disposed at a landfill licensed to accept such waste. Protective clothing is not required when handling these articles, but we recommend you follow the normal hygiene rules of not smoking, eating or drinking in the work area and always wash your hands before eating or drinking.
- Check that the appliance is clean and that soot or debris is not blocking the gaps between the ceramic fuel effect pieces causing an imperfect flame.
- Check that soot or debris is not impairing the electrode spark or pilot burner.
- Check that soot or debris is not blocking any of the slots in the main burner.
- After servicing, make sure that the ceramic walls are replaced and the ceramic fuel effect pieces are replaced correctly as described in the installer and owner guide supplied with the ceramic fuel effect. The ceramic fuel effect guide may have been placed inside or attached to this guide.
- **Always test for gas soundness and spillage after servicing the appliance.**

INSTALLER GUIDE

17.1 Checking the aeration setting of the burner.

1. The aeration shutter is factory set. It is important to ensure that the aeration setting is correct (See figure 35).
2. To adjust the aeration setting loosen the two aeration shutter screws, slide the aeration shutter to the desired position and tighten the fixing screws.

17.2 To remove the ignition microswitch.

See figure 36.

1. Remove the bottom front cover.
2. Disconnect the leads from the ignition microswitch (The lower of the two microswitches - See figure 36).
3. Detach the microswitch and insulation pad by removing two screws.
4. Replace in the reverse order. Check that the microswitch operates correctly by fully closing it and observing that there are sparks at the pilot electrode.

17.3 To remove the gas shut-off microswitch.

(See figures 36 & 37).

1. Remove the bottom front cover.
2. Loosen the thermocouple nut to free the microswitch leads and pull the leads clear of the thermocouple interrupter block (See figure 37).
4. Detach the bridging bracket, microswitch assembly by removing two screws (See figure 36).
5. Replace in the reverse order. When refitting the leads to the interrupter block, make sure that they are secured firmly to give a good electrical contact.

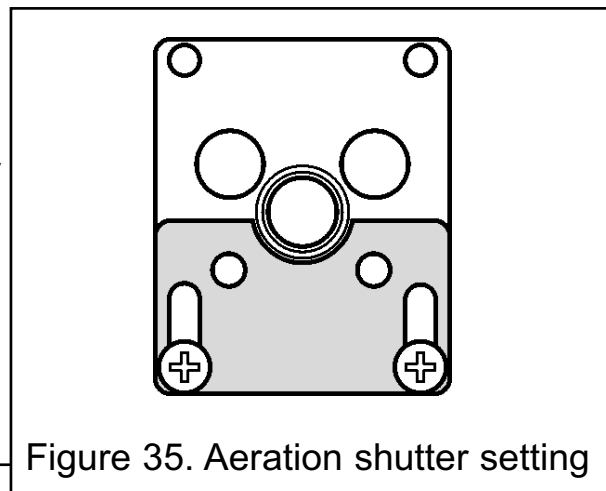

Figure 35. Aeration shutter setting

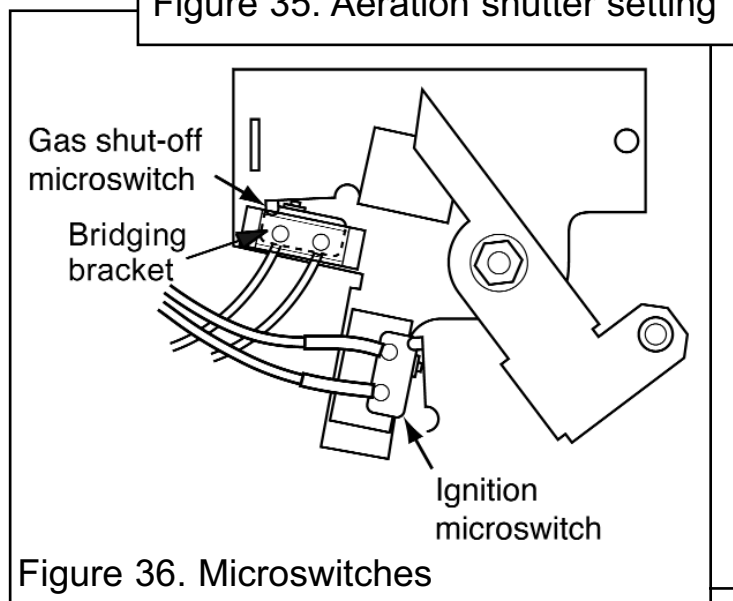

Figure 36. Microswitches

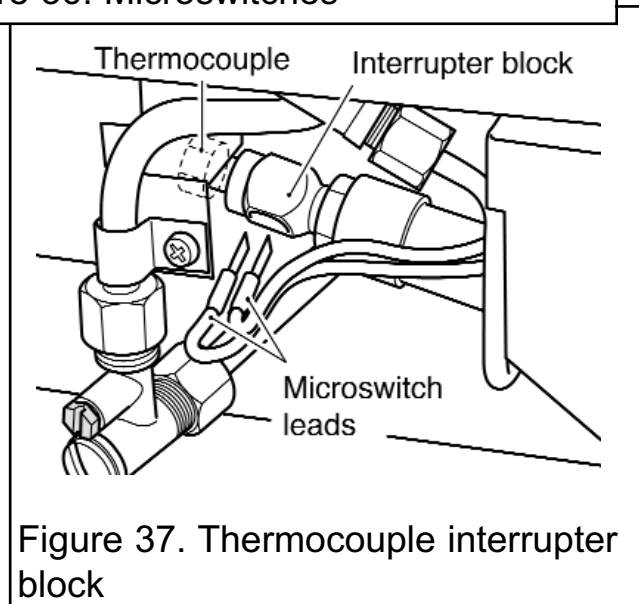

Figure 37. Thermocouple interrupter block

INSTALLER GUIDE

17.4 To remove the fascia.

For Bloomsbury and Ebony models.

1. Remove the bottom front cover and the fire front casting.
2. Remove the two knurled screws securing the bottom of the fascia to the sides of the convection box (See figure 38).
3. Carefully lift the fascia upward to clear the upper retaining brackets on the convection box. Pull the fascia clear and place carefully aside.
4. Refit in the reverse order. Make sure that the fascia is properly located over the upper retaining brackets. See section 15 of this guide for detailed fitting instructions. Please note that on Bloomsbury and Ebony models that the casting is not expected to sit flat against the fixing bracket. Tighten the knurled screws sufficiently to retain the casting, over tightening the screws will cause damage.

For Bauhaus models.

1. Remove the bottom front cover and the fire front casting.
2. Remove the two screws and washers securing the bottom of the fascia to the sides of the convection box (See figure 38).
3. Carefully lift the fascia upward to clear the upper retaining brackets on the convection box. Pull the fascia clear and place carefully aside.
4. Refit in the reverse order. Make sure that the fascia is properly located over the upper retaining brackets. See section 15 of this guide for detailed fitting instructions.

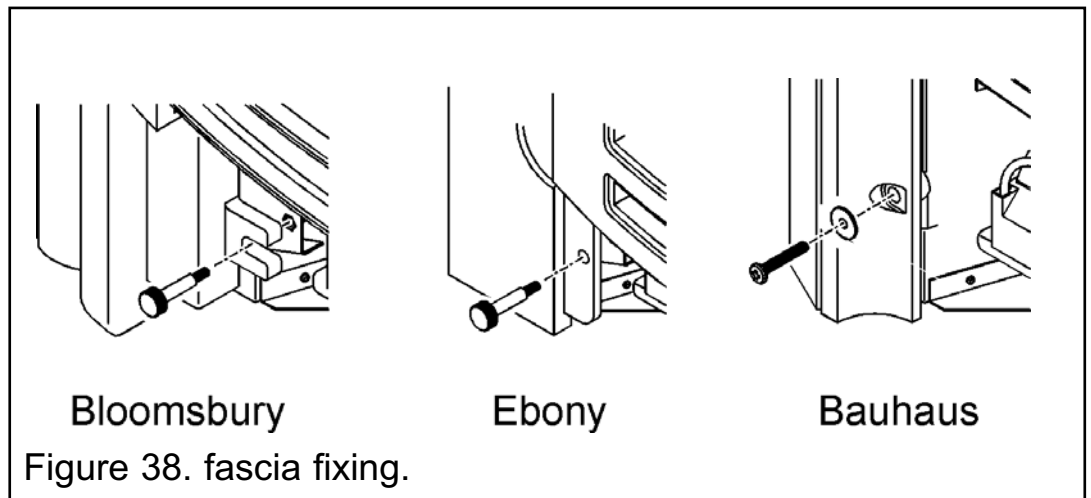

INSTALLER GUIDE

17.5 To replace the control slide unit.

1. Remove the fascia (See section 17.4).
2. Remove the knurled screw securing the control linking arm to the burner (See figure 39).
3. Detach the slide unit by removing two screws securing it to the convection box flange (See figure 40).
4. Replace in the reverse order.

17.6 To replace the control slide button.

1. Remove the fascia (See section 17.4).
2. Unscrew and remove the two screws securing the slide button to the slider mechanism.
3. Remove the button, replace and fit in the reverse order.

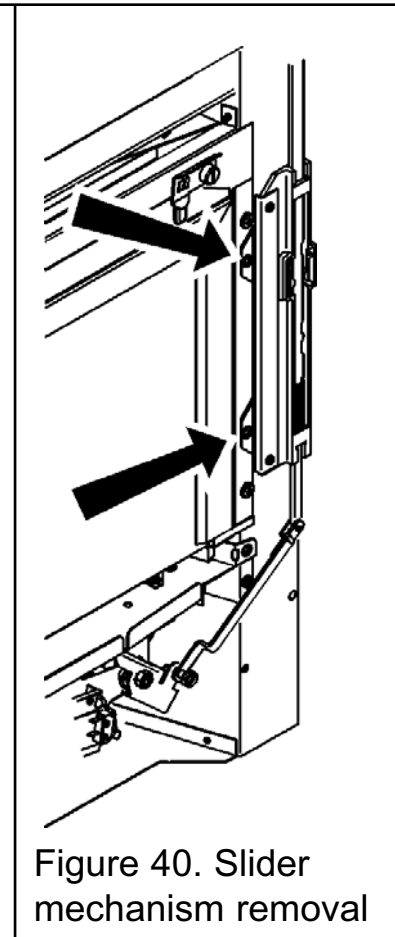
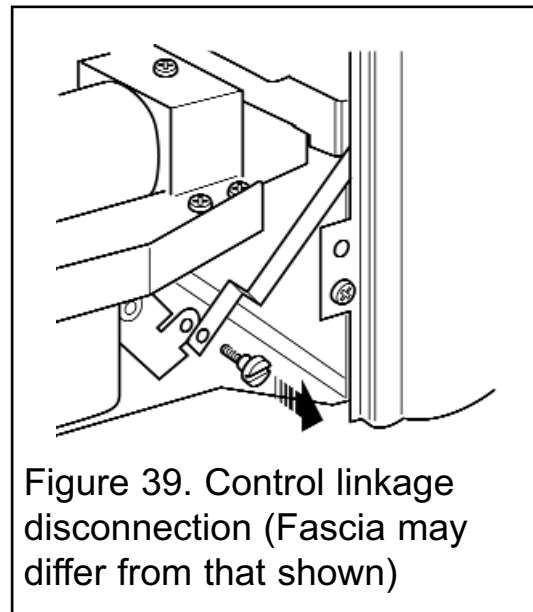

INSTALLER GUIDE

17.7 To remove and fit the window mounting frame and window assembly.

When servicing the appliance it will be necessary to remove all of the window mounting frame and the window assembly to enable the front coal, ceramic walls and burner to be removed.

1. Remove the fascia as in section 17.4.
2. Unscrew and remove the six screws that secure the window mounting frame and window assembly. Remove and place away from the work area (See figure 41).

17.8 To remove the window assembly.

To remove.

1. The window assembly is held in place with two brackets that rotate around a central pivot point. Push the brackets up and clear of the window assembly (See figure 42). Gently pull the top of the window forward and lift the window assembly clear of its support channels (See figure 43). Place the window assembly in a safe place away from the work area.

To fit.

1. Locate the bottom corners of the window assembly.
2. Gently push the window assembly into place and secure with the window clamping brackets. The window clamping brackets have a raised 'stop' that will prevent them being rotated too far.

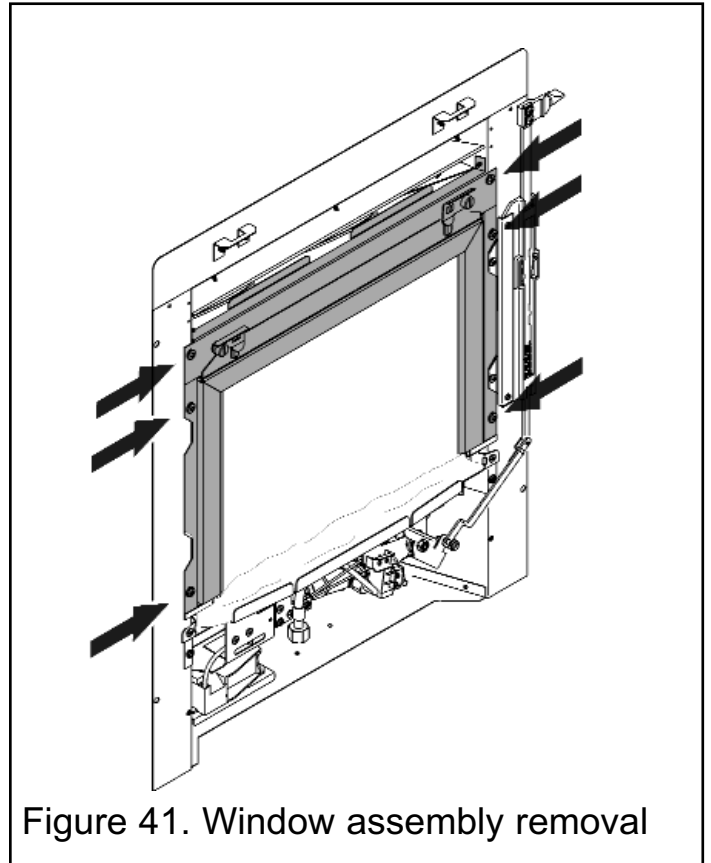

Figure 41. Window assembly removal

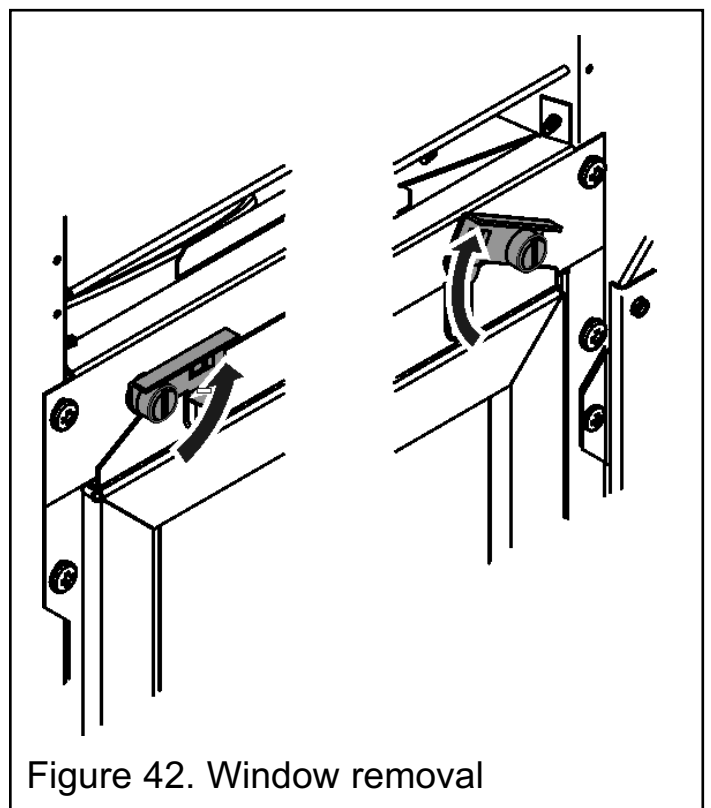

Figure 42. Window removal

INSTALLER GUIDE

17.9 To remove the fuel effect.

All of the fuel effect components except the front coal and ceramic walls can be removed by simply removing the window assembly as in this section 17.8. If the front coal or ceramic walls are to be replaced it will be necessary to remove the window frame and window assembly as in 17.7.

1. Remove the fuel effect in the reverse order to that shown for fitting in the ceramic guide. The ceramic fuel effect may cause staining / discolouration to decorative surfaces. It is therefore advisable to protect decorative surfaces.

2. Replace in the reverse order.

17.10 To remove the ceramic side walls.

1. Remove the window frame and window assembly as in section 17.7

2. Carefully slide the ceramic side walls forward to remove.

3. Carefully slide the ceramic rear wall upward to remove.

4. Replace in the reverse order.

17.11 To remove the electronic ignition generator.

1. Remove the window frame and window assembly as in section 17.7.

2. Remove the ceramic fuel effect as in section 17.9

3. Remove the alkaline battery.

4. Remove the spark lead.

5. Unscrew the four support bracket screws (See figure 44). The generator and its support bracket can now be moved forward. Be careful not to apply tension to the microswitch leads.

6. Remove the two fixing screws that attach the generator unit to the support bracket. The igniter generator can now be removed (See figure 44)

7. Remove the two leads to the switch and remove the spark lead. If necessary, mark them to ensure that they are replaced on to the correct terminals.

8. Replace the generator

9. Refit in the reverse order.

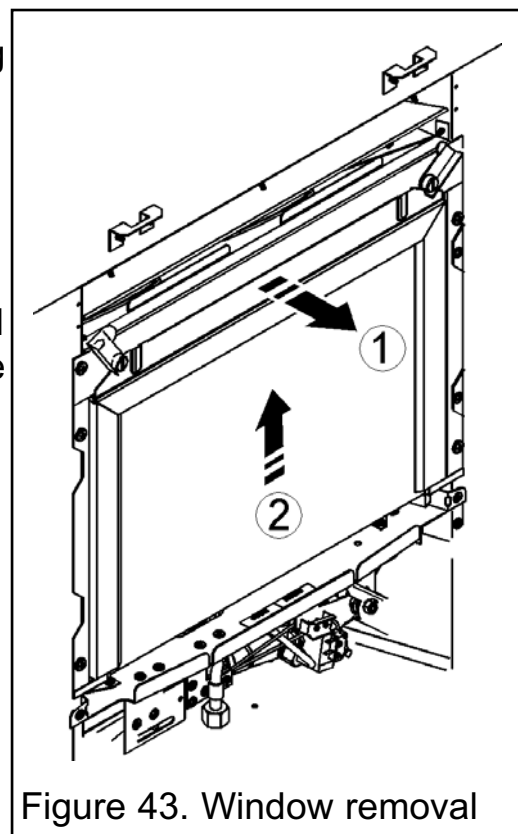

Figure 43. Window removal

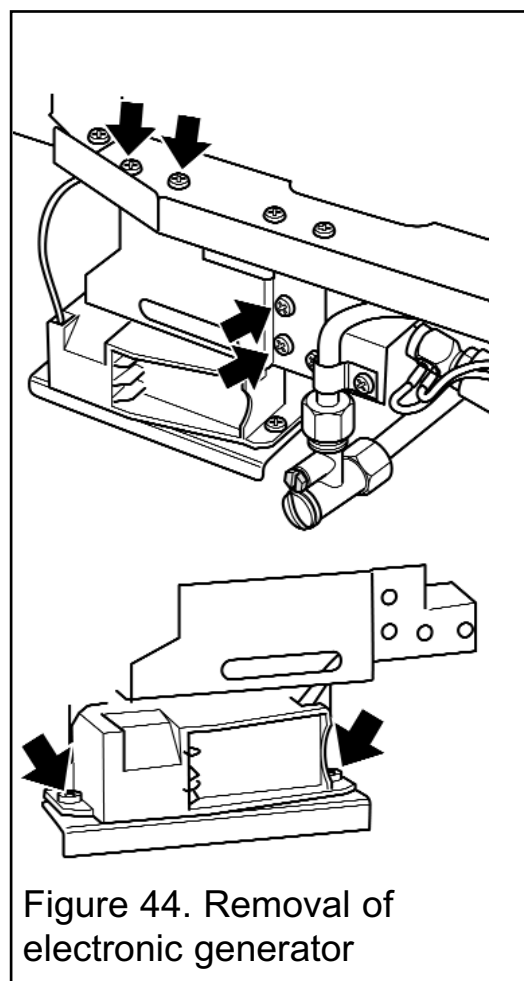

Figure 44. Removal of electronic generator

INSTALLER GUIDE

17.12 To remove the complete burner unit.

1. Remove the window frame and window assembly as in section 17.7.
2. Remove the ceramic fuel effect as in section 17.9
3. Close the isolating valve in the inlet 'T' connector. Support the inlet 'T' connector to avoid straining the pipework and disconnect the appliance from the 'T' connector.
4. Detach the burner unit from the convection box by removing two screws (See figure 45).
5. Replace in the reverse order.

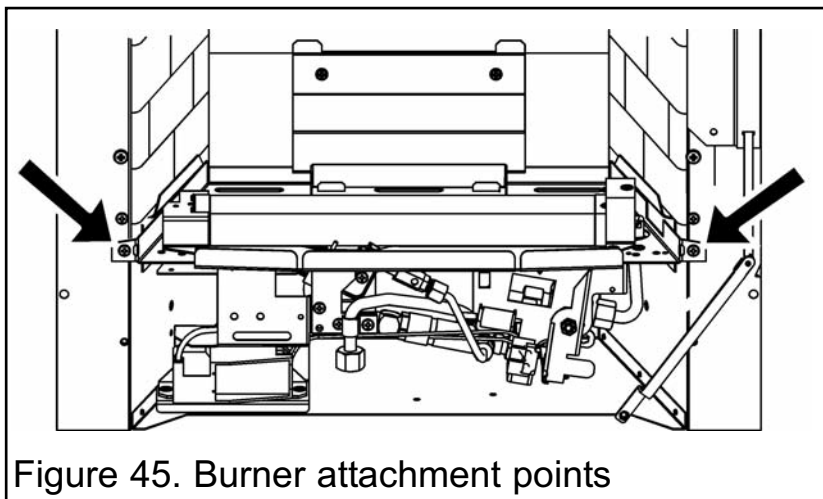

Figure 45. Burner attachment points

17.13 To remove the thermocouple interrupter block (See figure 37).

1. Remove the burner unit (See section 17.12).
2. Detach the thermocouple from the interrupter block by unscrewing the thermocouple nut.
3. Detach the two microswitch leads from the interrupter block.
4. Remove the interrupter block by unscrewing from the gas shut-off tap.
5. Refit in the reverse order. If the microswitch leads cannot be easily attached to the interrupter block when it is fully tightened to the gas shut-off tap, slacken it and rotate to allow the leads to be fitted. Tighten making sure that the leads remain in place in the interrupter block. Fit and tighten the thermocouple nut making sure that the leads are secured in the interrupter block to give a good electrical contact.

17.14 To remove the pilot unit.

1. Remove the burner unit (See section 17.12).
2. Detach the pilot pipe from the pilot unit.
3. Detach the thermocouple from the interrupter block by unscrewing the thermocouple nut.
4. Detach the electrode lead from the underside of the electrode tab.
5. Remove the two screws securing the pilot unit (See figure 46).
6. Refit in the reverse order.

Note: 1. The pilot unit is an atmosphere sensing device. It must be replaced as a whole assembly. Its individual components are not separately replaceable.

2. When the thermocouple is removed from the interrupter block, the microswitch lead terminals in the interrupter block will be loose. Make sure that they are properly secured to give a good electrical contact when tightening the thermocouple nut.

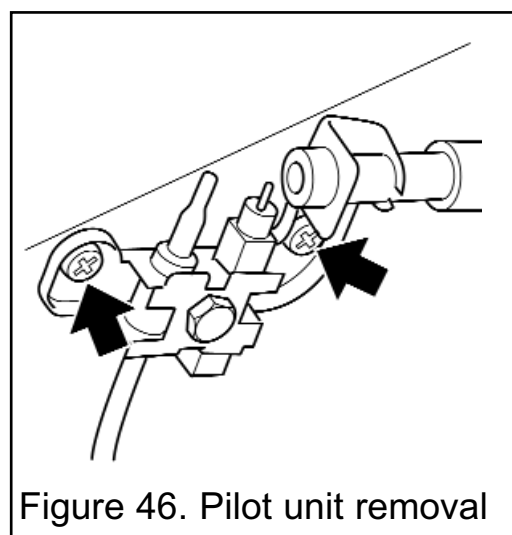

Figure 46. Pilot unit removal

INSTALLER GUIDE

17.15 To remove the shut-off tap.

(See figure 47).

1. Remove the burner unit (See section 17.12).
2. If lying the burner on its back, ensure that the work surface is suitably protected. This will avoid damage to the work surface. Turn the burner unit upside down. Detach the thermocouple and interrupter block from the tap (See section 17.13 paragraphs 2 - 4).
3. Detach the pilot pipe from the tap.
4. Detach the inlet pipe.
5. Remove the hexagonal nut securing the tap to the mounting bracket.
6. Detach the elbow by unfastening the hexagonal nut connecting it to the flow rate controller. Lift the tap (complete with elbow) clear.
7. Loosen the hexagonal locknut securing the elbow to the tap. Remove the elbow by rotating it.
8. If fitting a new tap, remove the hexagonal nut at the mounting bracket end of the old tap and fit to the replacement tap. Refit in the reverse order. When refitting, make sure that the tap spindle is in the correct relationship relative to the control pivot bracket. Rotate the pivot bracket fully clockwise. The tap spindle should "bottom out" (i.e. the tap should be fully open) after the pivot bracket has actuated the ignition microswitch but before it has pushed the microswitch leaf against the microswitch body.

When refitting the thermocouple and interrupter block, make sure that the microswitch wires are properly secured to give a good electrical contact.

17.16 To remove the gas flow rate controller.

(See figure 48).

1. Remove the burner unit (See section 17.12).
2. If lying the burner on its back, ensure that the work surface is suitably protected. This will avoid damage to the work surface.
3. Detach the shut-off tap as detailed in section 17.15 paragraphs 2-6.

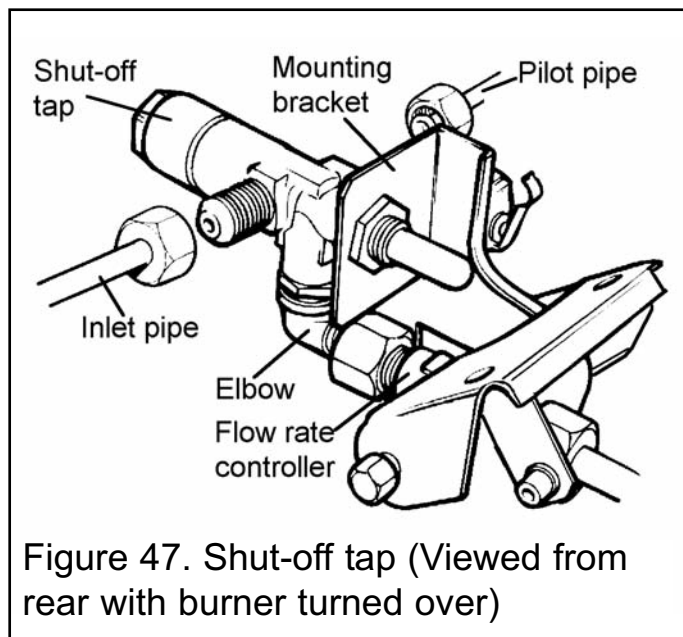

Figure 47. Shut-off tap (Viewed from rear with burner turned over)

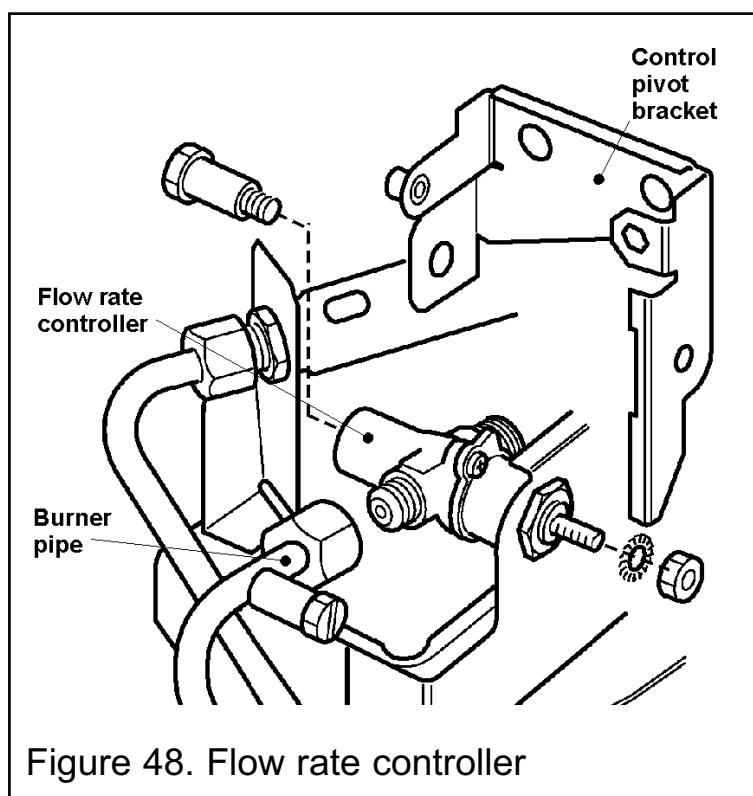

Figure 48. Flow rate controller

INSTALLER GUIDE

4. Detach the burner pipe from the controller. Support the controller while detaching to prevent excessive strain.
5. Remove the nut and washer securing the control pivot bracket to the controller at the front. Support the pivot bracket while removing the nut to prevent possible damage to the microswitch.
6. Remove the hexagonal bolt securing the control pivot bracket to the controller at the rear.
7. Detach the control pivot bracket.
8. Remove the hexagonal nut securing the controller to the front mounting bracket and remove the flow rate controller.
9. Refit in the reverse order.

17.17 To replace the burner.

(See figure 49).

1. Remove the burner unit (See section 17.12).
2. Support the elbow injector and unscrew the injector nut.
3. Remove the two screws from the burner clamping plate (See figure 49).
4. Lift the right hand side of the burner, slide it to the right and lift clear.
5. Refit in reverse order.

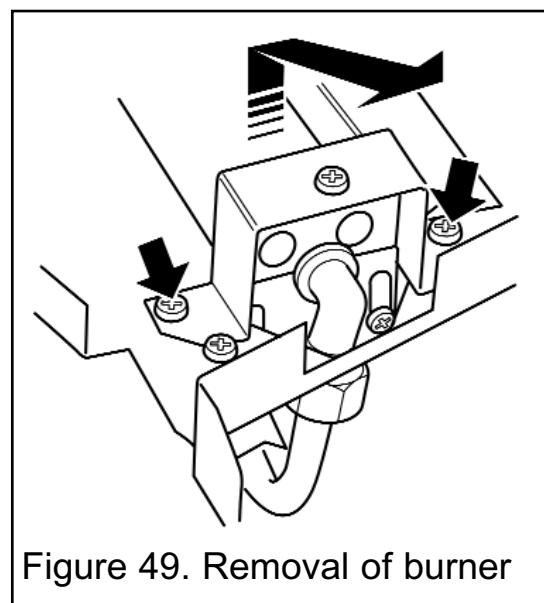

17.18 To remove the main burner injector.

(See figure 50).

1. Remove the burner (See section 17.17).
2. Remove the burner clamping screw (See figure 50).
3. Unscrew the injector from the burner.
4. Refit in the reverse order.

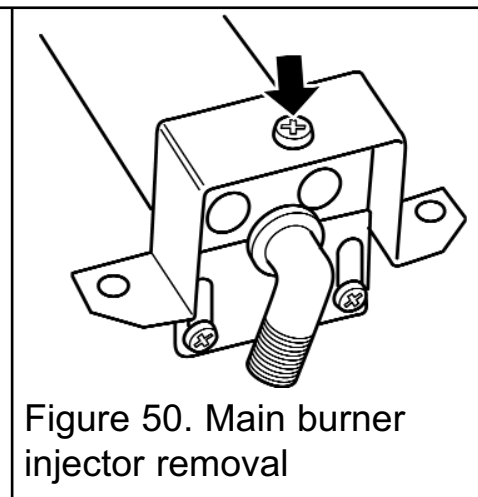

17.19 To remove the appliance from the fireplace.

1. Remove the burner unit (See section 17.12).
2. If the fire retention is as method 1 (See section 10.1 of this guide), remove the screws.
If the fire retention is as method 2 (See section 10.2 of this guide), slacken the hexagonal adjusters on the cable retainers and unscrew the thumbscrews to release the cables. Unscrew and remove the screws from the base of the convection box.

3. Refit as described in the relevant installation sections. Make sure gas soundness, sealing, spillage test and performance are satisfactory.

OWNER GUIDE

**FOR WARRANTY AND SERVICE INFORMATION
SEE PAGES 61 TO 67**

OWNER GUIDE

LIST OF CONTENTS

<u>Section</u>	<u>Page</u>
IMAGES	50
SAFETY	51
GAS CONSUMPTION	53
APPLIANCE DIMENSIONS	54
OPERATING YOUR FIRE	55
The Oxysafe flame sensing and flue blockage safety system.	55
To light the fire.	55
To turn the fire off.	56
Lighting with a taper.	56
HELP AND ADVICE	57
Ignition - Lighting the fire.	57
Window - Glass.	57
Fuel effect - Coal bed.	57
The rear and side wall effect.	57
CLEANING YOUR FIRE	58
Window assembly.	58
Glass and Metal parts.	58
Ceramic fuel effect pieces and burner compartment walls.	59
CERAMIC FUEL EFFECT FITTING	60
Alkaline battery replacement.	60
Burner.	60
MAINTENANCE	60
WARRANTY AND SERVICE	61

This gas fire is designed to meet the most stringent quality, performance and safety requirements to provide you with many years' trouble-free service.

This guide aims to improve your understanding and appreciation of your gas fire by providing simple and informative instructions to ensure that you benefit from the excellent performance and features it has to offer.

Ebony fascia



Bauhaus fascia

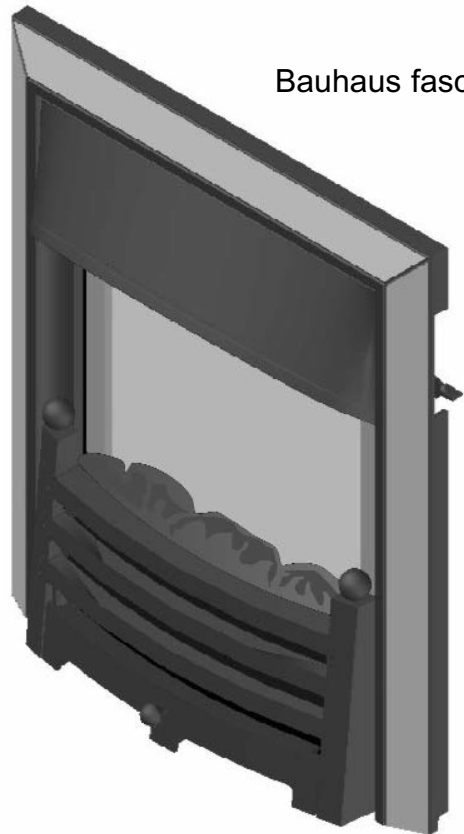

Bloomsbury fascia



IF YOU SMELL GAS

- **DON'T SMOKE.**
- **EXTINGUISH ALL NAKED FLAMES.**
- **DON'T TURN ELECTRICAL SWITCHES ON OR OFF.**
- **TURN OFF THE GAS SUPPLY AT THE METER.**
- **OPEN DOORS AND WINDOWS TO GET RID OF THE GAS.**
- **IMMEDIATELY CALL THE GAS EMERGENCY SERVICE FROM A NEIGHBOURS PHONE - SEE YOUR LOCAL TELEPHONE DIRECTORY.**

Do have the fire installed by a competent person. In the United Kingdom, installation must be in accordance with the latest edition of the Gas Safety (installation & use) Regulations. In the Republic of Ireland, installation must be in accordance with all national and local regulations in force.

Do have the chimney swept prior to installation if it was previously used for solid fuel.

Do have the fire installed in accordance with the installer guide.

Do provide a minimum clearance as shown in figure 1 above the base of the fireplace opening to any shelf made of wood or other combustible material. Please bear this in mind if you are making any alterations to the room.

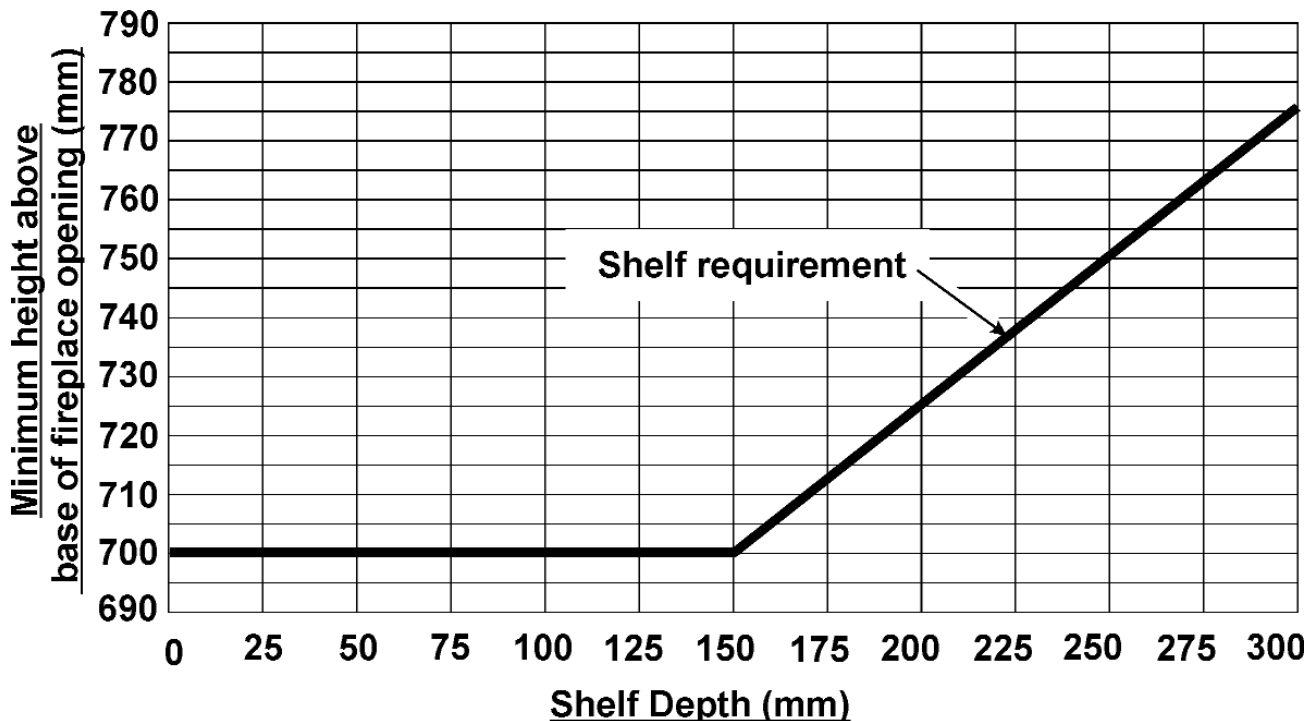

Figure 1. Combustible shelf clearances

OWNER GUIDE

Do provide a suitable guard that complies with BS 8423 for the protection of young children, the elderly and the infirm. Such a guard is also recommended for the protection of pet animals. (Although this fire conforms to all the applicable standards, it is a heating appliance and certain parts of its surface will become hot).

Do wait three minutes before attempting to relight if the fire is switched off or the flames are extinguished for any reason. (Your fire is fitted with a safety device that will automatically shut off the gas supply to the fire if, for any reason, the flames go out).

Do get advice about the suitability of any wall covering near your fire. Soft wall coverings (e.g. embossed vinyl, etc.) which have a raised pattern are easily affected by heat. They may, therefore, scorch or become discoloured when close to a heating appliance. Please bear this in mind whenever you are considering redecorating.

Do provide a minimum side clearance as detailed in figure 2. Please bear this in mind if ever you are considering altering the room.

Don't hang clothing, towels or any other fabrics over the fire.

Don't add any extra fuel effect pieces above the number stated in the ceramic fuel effect guide. This could cause a safety hazard. The ceramic fuel effect guide should have been attached to, or placed inside this guide by the installer.

Don't put paper or any other material on the fire.

Don't place any combustible material (rugs, carpet, plastic tiles, etc.) on the hearth (where fitted).

Don't attempt to clean or service the fire until it has been switched off and allowed to cool completely.

Don't use the fire without the window assembly fitted or if the window assembly is broken or damaged. The fire should be turned off and not used until the window unit is refitted with an authorised replacement.

Important: The canopy and upper horizontal casting area are classed as working surfaces. This means that they get very hot and are NOT to be touched during operation. When the fire is turned off these areas will take longer to cool.

OWNER GUIDE

GAS CONSUMPTION

Gross figures

Model 961

Has a maximum natural gas input of 5.0kW
Has a maximum natural gas output of 4.0kW

Has a minimum natural gas input of 2.5kW
Has a minimum natural gas output of 1.9kW

Net figures

Model 961

Has a maximum natural gas input of 4.5kW
Has a maximum natural gas output of 4.0kW

Has a minimum natural gas input of 2.25kW
Has a minimum natural gas output of 1.9kW

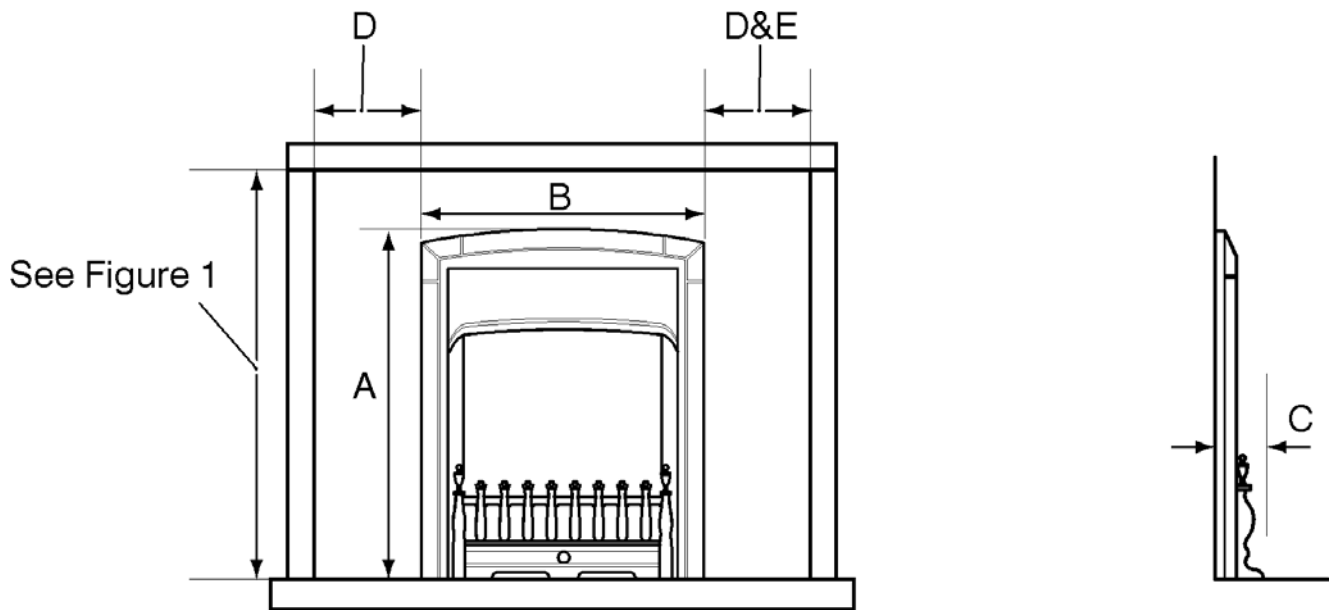

Key	Description	Model		
		Bauhaus	Bloomsbury	Ebony
A	Height (mm)	616	741	616
B	Width (mm)	518	588	518
C	Depth into room (mm)	117	127	126
D	Minimum mandatory clearance to combustible surfaces projecting beyond the front of appliance (mm).	100	100	100
E	Recommended clearance to non-combustible surfaces for access purposes (mm).	50	50	50

Figure 2. Appliance dimensions and clearances (The fascia may differ from that shown and dimensions are subject to manufacturing tolerances)

PLEASE NOTE

When operating your fire for the first time, some vapours may be given off which may cause a slight odour and could possibly set off any smoke alarms in the immediate vicinity. These vapours are quite normal with new appliances. They are totally harmless and will disappear after a few hours use.

The Oxysafe flame sensing and flue blockage safety system.

For your safety, this appliance is fitted with a flue blockage safety device which will shut down the appliance in the event of abnormal flue conditions. **This device is NOT a substitute for an independently mounted Carbon Monoxide detector.**

The device will also automatically shut off the gas supply to the fire if the pilot flame goes out due to lack of oxygen or for any other reason.

If this device starts to repeatedly shut off the gas, get expert advice.

This device incorporates a probe which senses that the heat from the pilot flame is correct. If this probe is cool, the device will prevent any gas flow unless the control knob is held in at the ignition position.

If, for any reason, the flames go out when the fire is hot or if the fire is turned off when hot, always **wait at least three minutes before attempting to relight.**

To light the fire.

The slide control is shown in figure 3.

1. Slide the control button to the bottom (ignition) position marked . In this position, the electronic ignition system should cause a series of sparks that should light the pilot. Within four seconds of the pilot igniting, the main burner should light at its minimum setting.

If no sparks are produced to light the pilot, the alkaline battery may need replacing. Details of alkaline battery replacement are given in the 'Maintenance' section of this guide.

Until you can obtain a replacement alkaline battery the fire can be lit with a taper as described later in this guide.

2. Keep the button at the ignition position for a further ten seconds. This will prevent the flame-sensing device from shutting off the gas while its probe warms up as explained above.

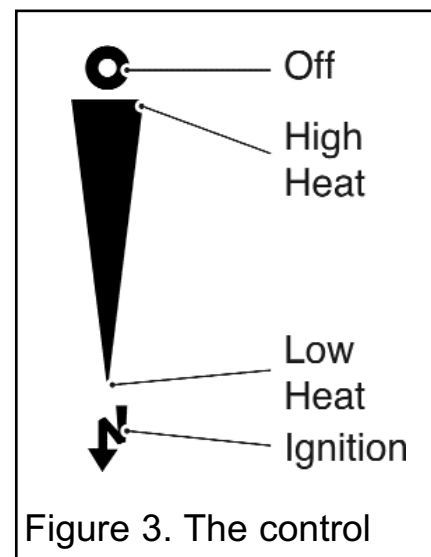

Figure 3. The control

OWNER GUIDE

3. If low heat is required, release the button. The button will automatically spring up to the low heat position shown in figure 3 (See note i below). If for any reason the slider control does not spring up, raise the slider to the off (O) position (Topmost position) and contact your installer. Do not use the fire until the problem has been rectified.

4. For a higher heat level slide the button upwards. The burner flames and heat output will gradually increase until the button reaches the high heat position shown in figure 3. When the button reaches the high heat position you will feel a check to its movement. **Do not slide the button above the high heat position unless you want to turn the fire off** (See note i below).

- Note
- i) If the flames go out while setting the control, repeat the full lighting procedure. If the flames repeatedly go out have the fire serviced.
 - ii) Please note. When first turned on the flames will appear predominantly blue. The ceramic fuel effect pieces will take time to warm up. Although some glow will be seen after approximately ten minutes, the full visual effect will only be apparent after a somewhat longer time.
 - iii) The appliance will operate to its maximum potential if the flue is primed during the first 20 – 30 minutes of operation. To do this, simply slide the control button to its highest setting. This will also burn off any carbon deposits that may have formed during previous operations.
 - iv) If operating the appliance for long periods it is beneficial occasionally to change the settings. This will also help to remove any carbon deposits that may form during operation.

To turn the fire off.

1. Slide the button up past the high heat position to the (O) position. Both the main burner and the pilot should go out. While cooling, the ceramic fuel effect pieces may make some crackling noises. This is quite normal.

Lighting with a taper.

Important: When lighting with a match or taper be very careful not to place naked flames by the plastic / rubber coated leads.

In the unlikely event of failure of the ignition spark, the pilot can be lit by a taper or long spill. To do this, remove the lower front casting and firefront casting then insert a taper or spill as shown in figure 4. Operate the slide control as described previously. **DO NOT ALLOW WAX OR OTHER DEPOSITS TO DROP ONTO THE PILOT.**

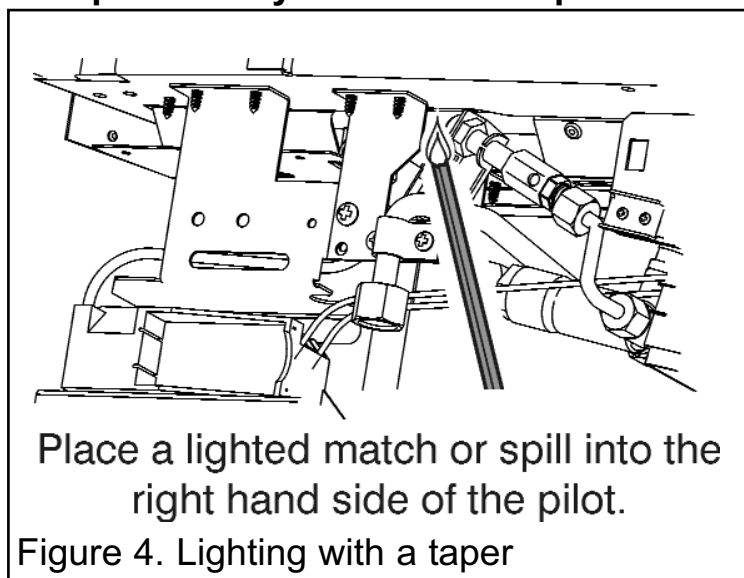

Ignition - Lighting the fire.

When you depress the Fireslide control you should hear a faint ticking sound from the bottom of the fire. This is the sound of the ignition spark that lights the gas. If there is no ticking sound it may be that the alkaline battery in the electronic spark generator requires replacement. Details of how to change the alkaline battery can be found in the 'MAINTENANCE' section of this guide.

Window - Glass.

Has the window formed white lines or appears milky or grey?

This is normal and is simply caused by the small amounts of condensation / water that form on the rear of the window during the first few minutes of operation. The condensation / water is no cause for concern and will disappear over the first few minutes of the fire being used. The window on the fire has been designed so that you can remove it for cleaning. Details on how to remove and clean the window can be found in the 'CLEANING YOUR FIRE' section of the owner guide.

Fuel effect - Coal bed.

When cleaning the ceramic fuel effect you may see surface cracks in the base coal. It is normal for the base coal to have surface cracks and this will not affect the performance of your fire in any way.

The fuel effect will lighten in colour with use and the areas where flames touch may develop brown edges. This is normal and is no cause for concern.

Does your fire have any signs of the following?

1. The fuel effect has areas that are black in colour (Much darker than the surrounding areas).
2. The fuel effect has areas that are black in colour and the flames are unusually long and dark yellow / orange.
3. Black dust / black particles on the hearth at the base of the fire.

Any of the above can be signs of soot forming in the fire. Please remember that we recommend the fire be serviced annually (Once a year) by a Gas Safe Register operative. If your fire is over 12 months old we strongly recommend that it is serviced.

The rear and side wall effect.

The rear and side walls are made from the same material as the fuel effect. As with the fuel effect, the wall effect will lighten in colour with use and the areas where flames touch may develop brown edges. To enhance the appearance of the fire and to produce more glow the flames have been designed to touch the rear wall. Where they touch light areas will form. This is normal and is no cause for concern.

To maintain the high performance and quality finish of your fire please follow these guidelines:

Before attempting to clean the fire, please remember to turn off the fire and wait for the appliance to cool. The fire will retain heat for some time before cleaning can begin.

If any pieces of debris are found in the firebox, have the chimney inspected before further use.

Glass and Metal parts.

- Clean the glass and metal parts with a slightly damp cloth and then dry.
- Do not use abrasive cleaners as these will scratch the fire surface.

Window assembly.

Removal of the window assembly is only necessary if you wish to clean the rear of the window or access the ceramic components. The window assembly can be cleaned with a mild detergent and water. Glass cleaner can also be used. Any stains on the glass can be removed with a non-abrasive cleaner such as a ceramic hob cleaner. Never use abrasive cleaners. Clean the window carefully in accordance with the instructions supplied with the cleaner.

Note:

When removing and fitting the window assembly care must be taken to ensure that the bottom of the glass is lifted high enough to clear the front ceramics and prevent damage to them. Ensure that the inside face of the window assembly is clean and free of fingerprints.

1. The window assembly is held in place with two clamping brackets that rotate around a central pivot point. Push the brackets up and clear of the window assembly (See figure 5). Gently pull the top of the window frame forward and lift the window assembly clear of its support channels (See figure 6). Place the window assembly in a safe place away from the work area.

2. Replace in the reverse order.

Ceramic fuel effect pieces and burner compartment walls.

To gain access to the ceramic components the window assembly must be removed as in the previous section.

It will not be possible to remove the ceramic compartment walls or ceramic front coal for cleaning. These must be cleaned in situ.

This product uses fuel effect pieces and burner compartment walls containing Refractory Ceramic Fibres (RCF), which are man-made vitreous silicate fibres. Excessive exposure to this material may cause irritation to eyes, skin and respiratory tract. Consequently, it is important to take care when handling these articles to ensure that the release of dust is kept to a minimum.

- Light coatings of soot will usually be burnt off during the normal operation of the fire. Should any soot accumulation become excessive, the one piece overlay coal and ceramic fuel effect base should be removed from the fire for cleaning. It will not be possible to remove the ceramic compartment walls or ceramic front coal for cleaning. These must be cleaned in situ.

- Cleaning should be carried out in a well ventilated area or in the open air by gently brushing with the pieces held away from your face so that you avoid inhaling the dust.

- We do not recommend the use of a normal domestic vacuum cleaner which may blow dust back into the air.

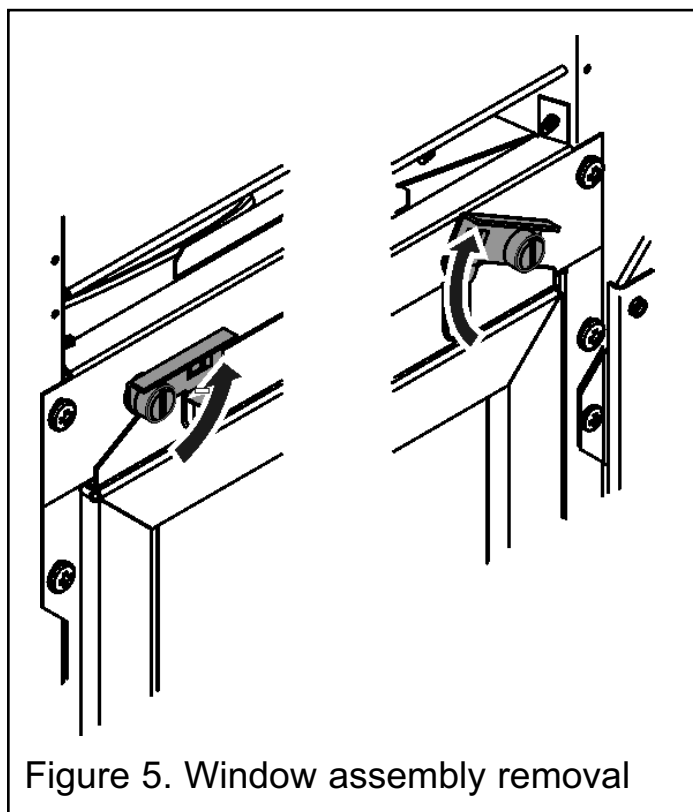

Figure 5. Window assembly removal

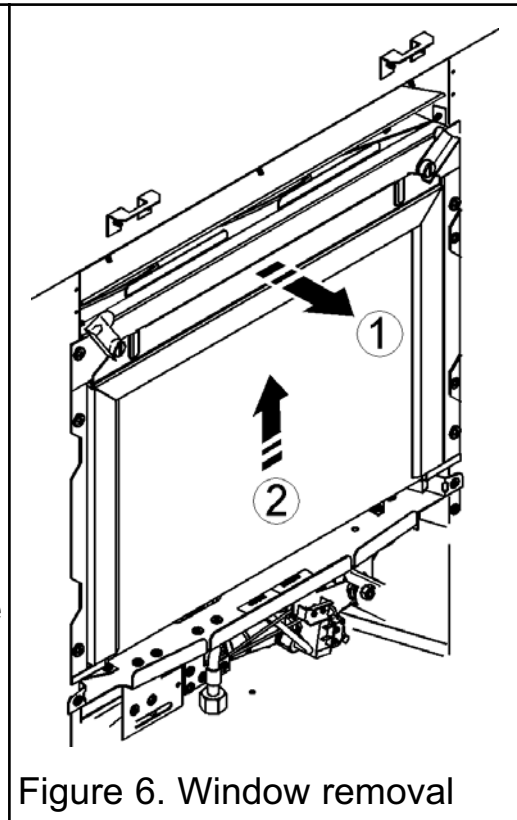

Figure 6. Window removal

OWNER GUIDE

- We suggest that you remove the ceramic fuel effect pieces in the reverse order to that shown in the ceramic fuel effect installer and owner guide.
- Once cleaned replace the fuel effect as in ceramic fuel effect installer and owner guide.

Burner.

To gain access to the burner the window assembly and ceramic components must be removed as in the previous sections. Be careful not to damage the front coal as this will be in situ.

Remove any deposits of soot or other foreign matter from the surface of the burner with a dry soft brush. Be careful not to brush any particles into the open slots. Remove any particles from the slots with a vacuum cleaner fitted with a soft brush attachment. **Do not poke wire, etc. into the slots in the burner.**

CLEANING FUEL EFFECT FITTING

- The installer and owner guide for the ceramic fuel effect is separate from this guide. The installer may have attached it to this guide or placed it inside. It is important that the installer and owner guide for the ceramic fuel effect is followed correctly. If replacing the ceramic fuel effect, where a new guide is supplied, follow the installer and owner guide supplied with the replacement fuel effect. Keep the replacement installer and owner guide with this owner guide for future reference.
- If you wish to replace any of the ceramic fuel effect pieces, spare parts are available nationwide via the 'interpart stockist network'. For your local stockist consult Yellow pages under Central Heating.

MAINTENANCE

Alkaline battery replacement.

- To replace the alkaline battery remove the bottom front cover casting.
- Fit the new alkaline battery firmly to the connections on the ignition block (See figure 7).

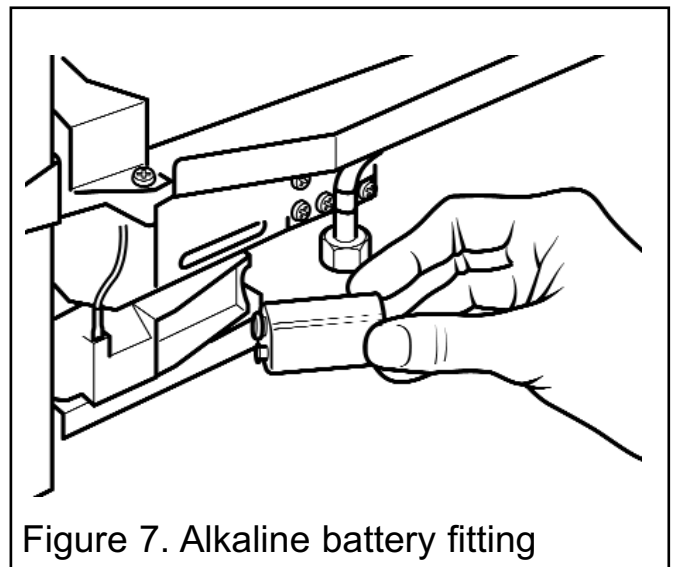

Figure 7. Alkaline battery fitting

OWNER GUIDE

Regular maintenance.

In order to achieve and maintain high levels of personal safety and performance efficiency, it is essential that the opening at the back of the fire and the flue are kept clear of any form of obstruction. It is possible that deposits of mortar or soot could fall and accumulate causing the flue to be blocked or restricted and so preventing proper clearance of dangerous exhaust fumes.

In the United Kingdom it is the law that a landlord must have any gas appliance, flue and pipework which is situated in a tenant's premises checked for safety at least every twelve months by a competent person (In the UK a GAS SAFE REGISTER operative).

We recommend that all gas appliances and their flues, wherever situated, are checked annually.

- **When fitting replacement parts it is important that only approved parts are used for maximum safety.**

WARRANTY AND SERVICE

Five Year Wonderfire Premier Warranty Terms & Conditions

To qualify for the five year warranty you will need to register your fire using the Warranty Booklet provided by the Wonderfire Premier Dealer at point of purchase.

If you did not receive a Warranty Booklet please contact your retailer where you purchased the fire. Please note the warranty is for Wonderfire Premier Fires only. If you have not registered your fire you are entitled to the standard 12 months warranty subject to contract.

It is a requirement of the warranty that the product is serviced annually. In the United Kingdom servicing can be carried out either by a **heateam** service operative or a **GAS SAFE REGISTER** operative. Outside of the United Kingdom servicing can be carried out either by a qualified and registered gas operative that meets the countries regulations for installation of a gas product. You must register your fire with **heateam** by completing and returning the Warranty Booklet provided by your Wonderfire Premier Dealer at point of purchase.

All services or maintenance work must be logged in the Warranty Booklet and validated with the operative's unique **Gas Safe Register** number.

Our promise to you

In the unlikely event that you experience a fault with your new fire, our aim is to provide an efficient, safe and quality service supported by our dedicated national network of highly skilled operatives. Nothing in this warranty will affect your statutory rights.

OWNER GUIDE

What you need to do if you experience a problem with the operation of the fire:

1. If the problem arises within 90 days of installation please contact your installer, because the cause of the fault may be related to the installation.
2. If your installer confirms that the installation has been undertaken correctly, please contact one of our friendly customer service team who are on hand to help.
3. Simply call our service division **heateam** on **0844 871 1554** to book an operative visit or for any general advice that you may need. **heateam** is open Monday to Friday 8am – 6pm, weekends and Bank Holidays 8.30am – 2pm, excluding Christmas Day and New Years day.

When calling heateam, it would be helpful if you could have the following information to hand:-

1. Fire serial number and fascia code (Located on the information label - See figure 8 on page 66)*.
 2. Date of installation*
 3. Your installer name and Gas Safe Register number*.
 4. Fire make and model number*.
 5. Proof of purchase (if you do not have the fire serial number).
- *Note: Details 1 – 4 should be recorded on pages 66 & 67 at the end of this guide.

5 Year Warranty Terms & Conditions

1. These terms and conditions are exclusively for the customers of Wonderfire Premier appointed dealers.
2. It is the responsibility of the customer to complete the warranty form to register the appliance with **heateam** (**heateam** is the service division of Wonderfire).
3. Responsibility cannot be accepted for registrations lost or delayed in the post. In addition, incomplete registrations will not be accepted.
4. Failure to complete all compulsory sections will result in the warranty not being activated and only the 12 month manufacturers' guarantee being applied.
5. This warranty is non-transferable and is made to the original owner.
6. The fire must only be used for domestic purposes, and this warranty only applies to fires purchased and used within the UK.
7. Gas fire installation must be carried out by a **Gas Safe Registered** operative in accordance with the installer and Owner Guide instructions supplied with the product. The product must only be operated in accordance with the Owner Guide.
8. The warranty period will be 60 calendar months from the date of purchase.
9. The first 12 months are covered by the standard manufacturers guarantee.
10. During the 48 month warranty period Wonderfire Premier will exchange or repair component[s] proved to be faulty from manufacture provided that such component[s] have been subject to normal conditions of use.

OWNER GUIDE

11. Gas fires must have an annual service, commencing 12 months after date of purchase by a **Gas Safe Registered operative** irrespective of use.
12. Proof of the completed services (if performed by third parties other than **heateam**) must be logged within the Warranty Booklet, along with the **Gas Safe operative's unique number**.
13. Failure to comply with the annual service requirements will result in only the standard 12 months manufacturers' guarantee being applied.
14. If the product is replaced the warranty period is not extended beyond the original period.
15. Wonderfire reserve the right to withdraw this warranty offer at any time.

Exclusions –This warranty DOES NOT COVER:

16. Servicing – servicing and the maintenance of the fire is the sole responsibility of the customer. Costs incurred in servicing and maintaining the fire cannot be recovered from the manufacturer (Wonderfire).
17. Parts that need to be replaced on a routine basis e.g coals and ceramic fuel effect components.
18. Cosmetic blemishes to polished metal and painted surfaces.
19. Fire surrounds and cabinets.
20. The cost of replacing any item or accessory that is intended to be replaceable. These include, but not restricted to: batteries, bulbs, plugs, fuses, ceramic fuel effect components, filters or igniters.
21. Fire trims are excluded from the cover.
22. Call out charges where faults are excluded from the warranty.
23. Faults caused by inadequate supply of gas or electricity (where applicable)
24. Wonderfire is not responsible for any damage caused by a third party.
25. Compensation or consequential losses (e.g. loss of earnings, business losses, stress and inconvenience) arising from a product breakdown, including repair delays caused by factors outside of our reasonable control.
26. The warranty is void if:
 - The fire has been operated in atmospheres contaminated by chlorine, fluorine or other damaging chemicals.
 - The fire is subjected to long periods of dampness or condensation within the atmosphere.
 - Any damage to components due to water or weather damage which is a result of, but not limited to, improper chimney or venting.
 - Any alteration, wilful abuse, accident, negligent or misuse of the product.
 - Theft or attempted theft.
 - Acts of God, explosions, floods, tempests, exceptional weather conditions, fire or accident.

OWNER GUIDE

To be completed by the installer:

Installer Details (Block Capitals)

Installer Name	
Gas Safe Register Number.	
Company Name.	
Company Address	
Company Telephone number	
Company Fax number	

Where to find the information label.

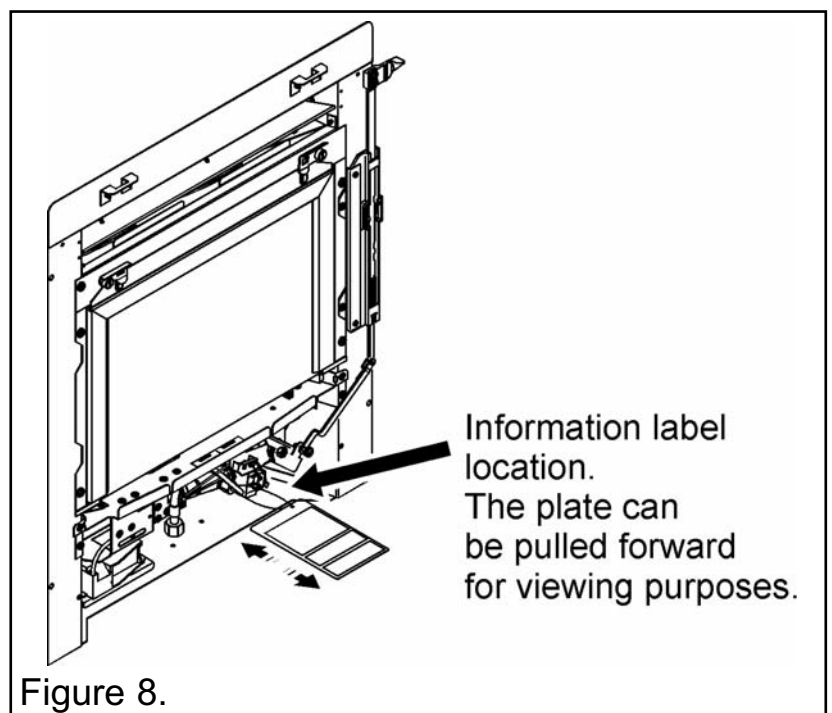

OWNER GUIDE

Model

9 6 1

Serial number (A label containing this information may have been placed below or can be found on the serial number label - See figure 8)

□ □ □ □ □ □ □ □ □ □ □ □ □ □

A LABEL CONTAINING THE SERIAL NUMBER MAY HAVE BEEN PLACED INSIDE THIS BOX.

SERIAL NUMBER LABEL
TO BE AFFIXED HERE

Fascia name (Block Capitals)

□ □ □ □ □ □ □ □ □ □

Fascia code - Can be found close to the information label (Block Capitals)

□ □ □ □ □ □ □ □ □ □ □ □ □ □

A LABEL CONTAINING THE FASCIA CODE MAY HAVE BEEN PLACED INSIDE THIS BOX.

FASCIA CODE LABEL
TO BE AFFIXED HERE

Brand

W O N D E R F I R E P R E M I E R

Date of Installation

□ □ □ □ □ □
D D M M Y Y

GC Number

3 2 - 0 3 2 - 8 8

